

Model 951C NO_x Analyzer



ESSENTIAL INSTRUCTIONS

READ THIS PAGE BEFORE PROCEEDING!

Rosemount Analytical designs, manufactures and tests its products to meet many national and international standards. Because these instruments are sophisticated technical products, you **MUST properly install, use, and maintain them** to ensure they continue to operate within their normal specifications. The following instructions **MUST be adhered to** and integrated into your safety program when installing, using, and maintaining Rosemount Analytical products. Failure to follow the proper instructions may cause any one of the following situations to occur: Loss of life; personal injury; property damage; damage to this instrument; and warranty invalidation.

- **Read all instructions** prior to installing, operating, and servicing the product.
- If you do not understand any of the instructions, **contact your Rosemount Analytical representative** for clarification.
- **Follow all warnings, cautions, and instructions** marked on and supplied with the product.
- **Inform and educate your personnel in the proper installation, operation, and maintenance of the product.**
- **Install your equipment as specified in the Installation Instructions of the appropriate Instruction Manual and per applicable local and national codes.** Connect all products to the proper electrical and pressure sources.
- To ensure proper performance, **use qualified personnel** to install, operate, update, program, and maintain the product.
- When replacement parts are required, ensure that qualified people use replacement parts specified by Rosemount. Unauthorized parts and procedures can affect the product's performance, place the safe operation of your process at risk, **and VOID YOUR WARRANTY.** Look-alike substitutions may result in fire, electrical hazards, or improper operation.
- **Ensure that all equipment doors are closed and protective covers are in place, except when maintenance is being performed by qualified persons, to prevent electrical shock and personal injury.**

The information contained in this document is subject to change without notice.

Teflon® is a registered trademark of E.I. duPont de Nemours and Co., Inc.

Alconox is a registered trademark of Alconox, Inc.

SNOOP® is a registered trademark of NUPRO Co.

WORLD HEADQUARTERS
Emerson Process Management
Rosemount Analytical Inc.
6565P Davis Industrial Parkway
Solon, OH 44139
T 440 914 1261
T 800 433 6076
F 440 914 1262
E gas.csc@emerson.com



HIGHLIGHTS OF CHANGES

EFFECTIVE JUNE 10, 2009

PAGE	SUMMARY
Cover	Updated photo, revision number, and release date
P-6	Removed Compliance section
1-1	Added Mid Range
1-2	Added Mid Range
3-1	Added Mid Range, Backlight over range feature, and a note, using the MID range, set the pressure regulator to 2.5 psig.
3-2	Added a photo of the Signal Board, Added a photo of the Signal Board Test Points, removed the signal board diagnostic jumpers (Figure 3-4)
3-3	Removed the Hi/Lo Range Select Jumper (Figure 3-5), Updated the PPM Range selection switch photo and table, removed the decimal point selection jumpers (Figure 3-7), added Configuration Jumper Settings (Figure 3-7)
3-6	Added step 3 to the Zero Calibration Section (In the Mid Range Configuration, Set the Sample Pressure Regulator to 2.5 psig), Added step 3 to the span calibration section (In the Mid Range Configuration, Set the Sample Pressure Regulator to 2.5 psig), Added step 6 to the span calibration section (Use R25 and R43 for fine adjustments to the display and recorder output.)
4-3	Updated the Signal Conditioning and Display section to reflect the current PCB's, updated the Circuit function section.
4-5	Updated the Analyzer Signal Conditioning Block Diagram
6-1	Updated the MATRIX
6-3	Updated the Replacement Parts List
List of Drawings	Added Drawing 1-1, 1-2, and 1-3
Back Cover	Updated Company addresses and contact information

TABLE OF CONTENTS

PREFACE	P-1
Definitions.....	P-1
Safety Summary.....	P-2
General Precautions For Handling And Storing High Pressure Gas Cylinders.....	P-5
Documentation.....	P-6
Condensed Startup And Calibration Procedure.....	P-7
1.0 DESCRIPTION AND SPECIFICATIONS	1-1
1-1 Overview.....	1-1
1-2 Typical Applications.....	1-1
1-3 Specifications.....	1-2
2.0 INSTALLATION	2-3
2-1 Unpacking.....	2-3
2-2 location.....	2-3
1-3 voltage requirements.....	2-3
1-4 Electrical Connections.....	2-3
a. Line Power Connections.....	2-3
b. Potentiometric Recorder Connections.....	2-3
c. Current Recorder Connections.....	2-3
1-5 Gas Requirements.....	2-5
a. Air (U.S.P. Breathing Grade).....	2-5
b. Span Gas.....	2-5
1-6 Sample Requirements.....	2-5
1-7 Gas Connections.....	2-5
1-8 Leak Test.....	2-6
3.0 OPERATION	3-1
3-1 Front Panel Indicators and Controls.....	3-1
a. Display.....	3-1
b. Range Selection.....	3-1
c. Sample Pressure Gauge.....	3-1
d. Ozone Pressure.....	3-1
e. Zero and Span Potentiometers.....	3-3
f. Ozone Interlock.....	3-3
3-2 Startup Procedure.....	3-3
3-3 Calibration.....	3-6
a. Zero Calibration.....	3-6
b. Upscale Calibration.....	3-6
3-4 Routine Operation.....	3-6
3-5 Converter Temperature Adjustment Procedure.....	3-6
3-6 Measurement of Converter Efficiency.....	3-9
3-7 Recommended Calibration Frequency.....	3-9
4.0 THEORY	4-1

4-1	Nitric Oxide Determination by Chemiluminescence Method	4-1
4-2	Analyzer Flow System	4-1
	a. Flow of Sample, Standard Gas or Zero Gas to Reaction Chamber	4-1
	b. Ozone Generation.....	4-1
4-3	Signal Conditioning And Display	4-2
	a. Circuit Functions	4-2
4-4	Analyzer Thermal System	4-3
5.0	ROUTINE SERVICING.....	5-1
5-1	System Checks and Adjustments.....	5-1
	a. Display Fullscale Span Adjustment.....	5-1
	b. Overall Sensitivity.....	5-1
	c. Ozone Output.....	5-2
	d. Background Current.....	5-2
5-2	Servicing Flow System	5-2
	a. Cleaning Sample Capillary.....	5-3
	b. Ozone Restrictor Fitting	5-3
5-3	Photomultiplier Tube/Reaction Chamber	5-4
	a. Removal	5-4
	b. Cleaning Reaction Chamber.....	5-4
	c. Photomultiplier Tube and Housing.....	5-5
	d. Replacement of Photomultiplier Tube.....	5-6
5-4	Ozone Generation System	5-6
	a. Lamp/Housing Removal.....	5-6
	b. UV Lamp Replacement.....	5-7
	c. Power Supply Removal.....	5-7
5-5	Converter Assembly	5-7
5-6	Servicing Electronic Circuitry.....	5-8
6.0	REPLACEMENT PARTS	6-1
6-1	Matrix	6-1
6-2	Circuit Board Replacement Policy.....	6-3
6-3	Replacement Parts	6-3
	a. Common Parts	6-3
	b. Photomultiplier Assembly 654062.....	6-4
	c. Converter Assembly 654070.....	6-5
	d. Temperature Control Assembly 654068	6-6
7.0	RETURN OF MATERIAL	7-2
7-1	return of material	7-2
7-2	customer service	7-2
7-3	Training.....	7-2
8.0	INDEX.....	8-1

LIST OF ILLUSTRATIONS

Figure 2-1. Power Supply Board Voltage Select Switches	2-2
Figure 2-2. Temperature Control Board	2-3
Figure 2-3. Cable Gland	2-3
Figure 2-4. Rear View of Model 951C (cover removed).....	2-4
Figure 2-5. Rear Panel Wiring Connections.....	2-4
Figure 3-1. Model 951C Controls, Indicators and Adjustments.....	3-2
Figure 3-2. Signal Board.....	3-3
Figure 3-3. Signal Board Test Points	3-3
Figure 3-6. PPM Range Select Switch	3-3
Figure 3-7. Configuration Jumper Settings.....	3-3
Figure 3-8. Range 2 Selection Jumpers.....	3-3
Figure 3-9. Power Supply Board	3-5
Figure 4-1. Analyzer Block Diagram.....	4-4
Figure 4-2. Analyzer Thermal System.....	4-5
Figure 6-1. Major Assemblies of the Model 951C	6-3
Figure 6-2. Photomultiplier Housing Assembly	6-4
Figure 6-3. Converter Assembly.....	6-5
Figure 6-4. Case Heater Temperature Control Assembly.....	6-6

LIST OF TABLES

Table 3-1. Resistance of Converter Temperature Sensor vs. Temperature	3-7
---	-----

LIST OF DRAWINGS

Drawing 1-1 Panel Cutout / Installation Drawing
Drawing 1-2 Flow Diagram, Lo/Mid Range
Drawing 1-3 Flow Diagram, Hi Range

PREFACE

The purpose of this manual is to provide information concerning the components, functions, installation and maintenance of the 951C NO_x Analyzer.

Some sections may describe equipment not used in your configuration. The user should become thoroughly familiar with the operation of this module before operating it. Read this instruction manual completely.

DEFINITIONS

The following definitions apply to DANGERS, WARNINGS, CAUTIONS and NOTES found throughout this publication.

DANGER

Highlights the presence of a hazard which will cause severe personal injury, death, or substantial property damage if the warning is ignored.

WARNING

Highlights an operation or maintenance procedure, practice, condition, statement, etc. If not strictly observed, could result in injury, death, or long-term health hazards of personnel.

CAUTION

Highlights an operation or maintenance procedure, practice, condition, statement, etc. If not strictly observed, could result in damage to or destruction of equipment, or loss of effectiveness.

NOTE

Highlights an essential operating procedure, condition or statement.

SAFETY SUMMARY

If this equipment is used in a manner not specified in these instructions, protective systems may be impaired.

AUTHORIZED PERSONNEL

To avoid explosion, loss of life, personal injury and damage to this equipment and on-site property, all personnel authorized to install, operate and service the this equipment should be thoroughly familiar with and strictly follow the instructions in this manual. **SAVE THESE INSTRUCTIONS.**

DANGER

ELECTRICAL SHOCK HAZARD

Do not operate without doors and covers secure. Servicing requires access to live parts which can cause death or serious injury. Refer servicing to qualified personnel.

This instrument was shipped from factory set up to operate on 115 volt 50/60 Hz. For operation on 230 volt 50/60 Hz, refer to Section 2-3.

For safety and proper performance this instrument must be connected to a properly grounded three-wire source of power.

WARNING

INTERNAL ULTRAVIOLET LIGHT HAZARD

Ultraviolet light from the ozone generator can cause permanent eye damage. Do not look directly at the ultraviolet source in ozone generator. Use of ultraviolet filtering glasses is recommended.

WARNING**TOXIC CHEMICAL HAZARD**

This instrument generates ozone which is toxic by inhalation and is a strong irritant to throat and lungs. Ozone is also a strong oxidizing agent. Its presence is detected by a characteristic pungent odor.

The instrument exhaust contains both ozone and nitrogen dioxide, both toxic by inhalation, and may contain other constituents of the sample gas which may be toxic. Such gases include various oxides of nitrogen, unburned hydrocarbons, carbon monoxide and other products of combustion reactions. Carbon monoxide is highly toxic and can cause headache, nausea, loss of consciousness, and death.

Avoid inhalation of the ozone produced within the analyzer and avoid inhalation of the sample and exhaust products transported within the analyzer. Avoid inhalation of the combined exhaust products at the exhaust fitting.

Keep all tube fittings tight to avoid leaks. See Section 2-8 for Leak Test Procedure.

Connect rear exhaust outlet to outside vent by a 1/4 inch (6.3 mm) or larger stainless steel or Teflon line. Check vent line and connections for leakage.

WARNING**PARTS INTEGRITY**

Tampering or unauthorized substitution of components may adversely affect safety of this product. Use only factory documented components for repair.

WARNING**HIGH PRESSURE GAS CYLINDERS**

This instrument requires periodic calibration with a known standard gas. See Sections 2-5 and 3-3. See also General Precautions for Handling and Storing High Pressure Gas Cylinders, page P-5.

WARNING

TOXIC AND OXIDIZING GAS HAZARD

The ozone generator lamp contains mercury. Lamp breakage could result in mercury exposure. Mercury is highly toxic if absorbed through skin or ingested, or if vapors are inhaled.

HANDLE LAMP ASSEMBLY WITH EXTREME CARE

If lamp is broken, avoid skin contact and inhalation in the area of the lamp or the mercury spill.

- Immediately clean up and dispose of the mercury spill and lamp residue as follows:
- Wearing rubber gloves and goggles, collect all droplets of mercury by means of a suction pump and aspirator bottle with long capillary tube. Alternatively, a commercially available mercury spill clean-up kit, such as J. T. Baker product No. 4439-01, is recommended.
- Carefully sweep any remaining mercury and lamp debris into a dust pan. Carefully transfer all mercury, lamp residue and debris into a plastic bottle which can be tightly capped. Label and return to hazardous material reclamation center.
- Do not place in trash, incinerate or flush down sewer.
- Cover any fine droplets of mercury in non-accessible crevices with calcium polysulfide and sulfur dust.

WARNING

TOPPLING HAZARD

This instrument's internal pullout chassis is equipped with a safety stop latch located on the left side of the chassis.

When extracting the chassis, verify that the safety latch is in its proper (counter-clockwise) orientation.

If access to the rear of the chassis is required, the safety stop may be overridden by lifting the latch; however, further extraction must be done very carefully to insure the chassis does not fall out of its enclosure.

If the instrument is located on top of a table or bench near the edge, and the chassis is extracted, it must be supported to prevent toppling.

Failure to observe these precautions could result in personal injury and/or damage to the product.

GENERAL PRECAUTIONS FOR HANDLING AND STORING HIGH PRESSURE GAS CYLINDERS

Edited from selected paragraphs of the Compressed Gas Association's "Handbook of Compressed Gases" published in 1981

Compressed Gas Association
1235 Jefferson Davis Highway
Arlington, Virginia 22202

Used by Permission

1. Never drop cylinders or permit them to strike each other violently.
2. Cylinders may be stored in the open, but in such cases, should be protected against extremes of weather and, to prevent rusting, from the dampness of the ground. Cylinders should be stored in the shade when located in areas where extreme temperatures are prevalent.
3. The valve protection cap should be left on each cylinder until it has been secured against a wall or bench, or placed in a cylinder stand, and is ready to be used.
4. Avoid dragging, rolling, or sliding cylinders, even for a short distance; they should be moved by using a suitable hand-truck.
5. Never tamper with safety devices in valves or cylinders.
6. Do not store full and empty cylinders together. Serious suckback can occur when an empty cylinder is attached to a pressurized system.
7. No part of cylinder should be subjected to a temperature higher than 125°F (52°C). A flame should never be permitted to come in contact with any part of a compressed gas cylinder.
8. Do not place cylinders where they may become part of an electric circuit. When electric arc welding, precautions must be taken to prevent striking an arc against the cylinder.

DOCUMENTATION

The following 951C instruction materials are available. Contact Customer Service Center or the local representative to order.

748214 Instruction Manual (this document)

CONDENSED STARTUP AND CALIBRATION PROCEDURE

The following summarized instructions on startup and calibration are intended for operators already familiar with the analyzer.

For initial startup, refer to detailed instructions provided in Section 3.

1. Review the Purchase Order from the 951C Analyzer. Make a note of the Range that was purchase (Low Range, Mid Range, or High Range).
2. Set Range switch on the Signal Conditioning Board to position 4, 250ppm, 500ppm, or 2500 ppm (see Figure 3-2, page 3-2).
3. On the Signal Conditioning Board, Verify that Hi/Mid/Lo Range Configuration Jumpers are installed for the Range that was purchase (Figure 3-7, page 3-3)
4. Apply power to the analyzer. The analyzer will now require approximately one to two hours for temperature equilibrium before being ready for calibration.
5. Verify that the pressure regulator on the cylinder of zero gas (nitrogen or air) or sample gas is set for supply pressure of 10 to 17 psig.
6. Verify that the pressure regulator on the cylinder of air (ozonator supply) is set for supply pressure of 20 to 25 psig.
7. Establish correct pressure of sample gas:
 - a. Supply sample gas to rear-panel SAMPLE inlet at 10 to 17 psig (normally 15 psig).
 - b. Adjust SAMPLE Back Pressure Regulator so that SAMPLE Pressure Gauge indicates the value appropriate to the desired operating range (normal operating pressure is 3 to 5 psig). Using the Mid range setting, set the sample pressure regulator to 2.5 psig See Figure 3-1.
8. Establish correct pressure of zero gas:
 - a. Supply zero gas to rear panel SAMPLE inlet and set to 15 psig.
 - b. Note reading on SAMPLE Pressure Gauge. It should be the same as in Step 6b. If not, adjust output pressure regulator on the zero gas cylinder as required.
7. Establish correct pressure of upscale standard gas:
 - a. Supply upscale standard gas to rear panel SAMPLE inlet.
 - b. Note reading on SAMPLE Pressure Gauge. It should be the same as in Step 7b. If not, adjust output regulator on cylinder of upscale standard gas as required.

NOTE

Supply pressure for sample, upscale standard gas and zero air must be the same. If not, the readout will be in error.

8. Zero Calibration:
 - a. Set PPM RANGE Switch (Figure 3-6, page 3-3) for range to be used for sample analysis. Set the front panel RANGE1 Control at normal operating setting, if known, or at about middle or the range if normal setting is not known.
 - b. Supply zero gas to rear panel SAMPLE inlet.
 - c. Adjust front panel ZERO Control for reading of zero on meter or recorder.
9. Upscale Calibration:
 - a. Set PPM RANGE Switch (Figure 3-6, page 3-3) at setting appropriate to the particular span gas.

- b. Supply upscale standard gas of accurately known NO_x content to rear panel SAMPLE inlet.
- c. Adjust front panel RANGE1 Control so that reading on meter or recorder is equal to the known parts-per-million concentration of NO_x in the span gas.
- d. Adjust R25 on the signal board so that the Display value and the recorder output are equal.

NOTE

It is the responsibility of the user to measure efficiency of the NO_2 -to- NO converter during initial startup, and thereafter at intervals appropriate to the application, normally once a month.

SECTION 1

DESCRIPTION AND SPECIFICATIONS

1-1 OVERVIEW

The Model 951C NO_x Analyzer is designed to measure NO_x using one of three sets of ranges designated as Hi, Mid, or Lo. The Hi Range set consists of spans with ranges of 0-100, 0-250, 0-1000, and 0-2500 ppm NO_x. The Mid Range set consists of spans with ranges of 0-20, 0-50, 0-200, and 0-500 ppm NO_x. The Lo Range set consists of spans with ranges of 0-10, 0-25, 0-100, and 0-250 ppm NO_x.

The NO_x analyzer continuously analyzes a flowing gas sample for NO_x [nitric oxide (NO) plus nitrogen dioxide (NO₂)]. The sum of the concentrations is continuously reported as NO_x.

The analyzer is based on the chemiluminescence method of NO detection. The sample is continuously passed through a heated bed of vitreous carbon, in which NO₂ is reduced to NO. Any NO initially present in the sample passes through the converter unchanged, and any NO₂ is converted to an approximately equivalent (95%) amount of NO.

The NO is quantitatively converted to NO₂ by gas-phase oxidation with molecular ozone produced within the analyzer from air supplied by an external cylinder. During this reaction, approximately 10% of the NO₂ molecules are elevated to an electronically excited state, followed by immediate decay to the non-excited state, accompanied by emission of photons. These photons are detected by a photomultiplier tube, which in turn generates a DC current proportional to the concentration of NO_x in the sample stream. The current is then amplified and used to drive a front panel display and to provide potentiometric and isolated current outputs.

To minimize system response time, an internal sample-bypass feature provides high-velocity sample flow through the analyzer.

The Backlight blinks when the analyzer is 10% or more over-range. Selecting a less sensitive (higher) range restores the display function.

The case heater assembly of the Model 951C maintains the internal temperature at approximately 50°C (122°F).

1-2 TYPICAL APPLICATIONS

The Model 951C Analyzer has specific applications in the following areas:

- Oxides of nitrogen (NO_x) emissions from the combustion of fossil fuels in:
 - Vehicle engine exhaust
 - Incinerators
 - Boilers
 - Gas appliances
 - Turbine exhaust
- Nitric acid plant emissions
- Ammonia in pollution control equipment (with converter)
- Nitric oxide emissions from decaying organic material (i.e., landfills).

1-3 SPECIFICATIONS

Ranges

Lo.....	0 to 10, 0 to 25, 0 to 100, 0 to 250 ppm NO _x
Mid.....	0 to 20, 0 to 50, 0 to 200, 0 to 500 ppm NO _x
Hi.....	0 to 100, 0 to 250, 0 to 1000, 0 to 2500 ppm NO _x
Repeatability.....	within 0.1 ppm or ±1% of fullscale, whichever is greater
Zero/Span Drift.....	less than ±0.1 ppm or ±1% of fullscale, whichever is greater, in 24 hours at constant temperature
	less than ±0.2 ppm or ±2% of fullscale, whichever is greater, over any 10°C interval from 4 to 40°C (for rate change of 10°C or less per hour)

Response Time

(Electronic + Flow)	90% of fullscale in less than 1 minute
Sensitivity	less than 0.1 ppm or 1% of fullscale, whichever is greater
Detector Operating Pressure.....	atmospheric
Total Sample Flow Rate	1 Liter per minute at 20 psig
Sample Pressure	138 kPa (20 psig)
Ozone Generator Gas	U.S.P. breathing-grade air
Ambient Temperature Range	4 to 40°C (40 to 104°F)

Analog Output

Potentiometric.....	0 to +5 VDC, 2000 ohm minimum load
Isolated Current	Field-selectable 0 to 20 or 4 to 20 mA, 700 ohm max load
Display	Digital, 4-1/2 digit LCD, readout in engineering units, back-lighted
Power Requirements.....	115/230 VAC ±10%, 50/60 ±3 Hz, 570 W maximum
Enclosure.....	General purpose for installation in weather-protected areas
Dimensions.....	8.7 in. x 19.0 x 19.0 in. (H x W x D)
	22.0 cm x 48.3 cm x 48.3 cm (H x W x D)
Weight	22.2 kg (49 lbs) approximate

SECTION 2 INSTALLATION

2-1 UNPACKING

Carefully examine the shipping carton and contents for signs of damage. Immediately notify the shipping carrier if the carton or its contents are damaged. Retain the carton and packing material until the instrument is operational.

2-2 LOCATION

See drawing 654063 for Outline and Mounting dimensions.

Install analyzer in a clean area, free from moisture and excessive vibration, at a stable temperature within 4 to 40°C.

The analyzer should be mounted near the sample source to minimize sample-transport time.

A temperature control system maintains the internal temperature of analyzer at 50°C (122°F) to ensure proper operation over an ambient temperature range of 4°C to 40°C (40°F to 104°F). Temperatures outside these limits necessitate use of special temperature-controlling equipment or environmental protection. Also, the ambient temperature should not change at a rate exceeding 10°C/hr.

The cylinders of air and span gas should be located in an area of constant ambient temperature ($\pm 10^\circ\text{C}$).

2-3 VOLTAGE REQUIREMENTS

WARNING

ELECTRICAL SHOCK HAZARD

For safety and proper performance this instrument must be connected to a properly grounded three-wire source of power.

This instrument was shipped from the factory set up to operate on 115 VAC, 50/60 Hz electric power. For operation on 230 VAC, 50/60 Hz, on

the Power Supply Board (Figure 3-9, page 3-5) position voltage select switches S1, S2, S3 (Figure 2-1, page 2-2) and S3 (located on the Temperature Control Board (Figure 2-2, page 2-2) in the 230 VAC position.

Refer to Figure 2-4, page 2-3. On the rear of the analyzer, remove the 6.25 A fuse (P/N 902413) and replace with the 3.15 A fuse (P/N 898587) provided in the shipping kit.

2-4 ELECTRICAL CONNECTIONS

The power and output (recorder and current) cable glands are supplied loose in the shipping kit to allow cable installation to connectors or terminal strips.

<u>Cable</u>	<u>Gland Part No.</u>
Power	899330
Recorder	899329

Remove rear cover to access terminals. Route each cable through the cable gland and connect to the appropriate connector or terminal strip, tighten the gland.

a. Line Power Connections

Refer to Figure 2-3 (page 2-3), Figure 2-4 (page 2-3), Figure 2-5 (page 2-4) and drawing 654063. If this instrument is located on a bench or table top or is installed in a protected rack, panel or cabinet, power may be connected via a 3-wire flexible power cord, minimum 18 AWG (max. O.D. 0.480", min. O./D. 0.270"), through the hole labeled POWER, utilizing connector gland (P/N 899330) provided.

Route the power cable through the cable gland and connect the leads to TB1 on the rear panel. Tighten the cable gland adequately to prevent rotation or slippage of the power cable. Since the rear terminals do not slide out with the chassis, no excess power cable slack is necessary.

The following power cord and/or support feet (for bench top use) are available:

- Power Cord 634061
- North American power cord set (10 foot)
- Enclosure Support Kit 634958
- Enclosure support feet (4)
- Power Cord/Enclosure Support Kit 654008

- North American power cord set (10 foot)
- Enclosure support feet (4)

If the instrument is permanently mounted in an open panel or rack, use electrical metal tubing or conduit.

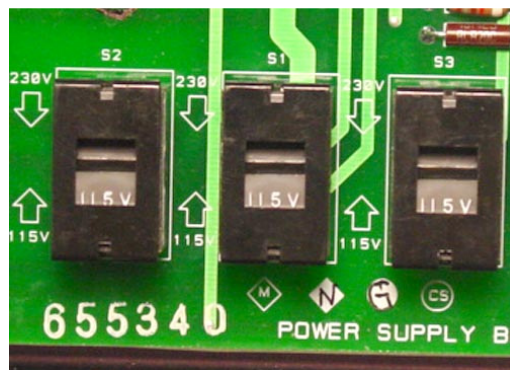

Set switch window for voltage required.

Figure 2-1. Power Supply Board Voltage Select Switches

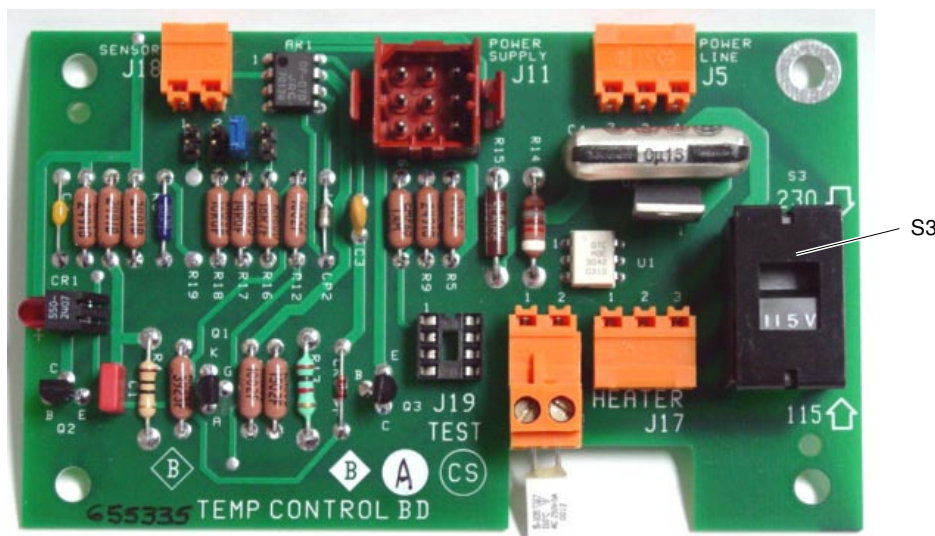

Set switch window for voltage required.

Figure 2-2. Temperature Control Board

Model 951C

b. Potentiometric Recorder Connections

Refer to Figure 2-3 (below), Figure 2-5 (page 2-4) and drawing 654063. Potentiometric recorder connections are made on the rear panel. Route the potentiometric recorder cable through the cable gland in the hole labeled RECORDER OUTPUT and connect to VOLT OUTPUT terminals.

Potentiometric recorder cable specifications are as follows:

- Distance from recorder to analyzer: 1000 feet (305 meters) maximum
- Input impedance: Greater than 2000 ohms
- Cable (user supplied): Two-conductor, shielded, min. 20 AWG
- Voltage output: 0 to +5 VDC

c. Current Recorder Connections

Refer to Figure 2-3 (below), Figure 2-5 (page 2-4) and drawing 654063. Current recorder connections are made on the rear panel. Route the current recorder cable through the cable gland in the hole labeled RECORDER OUTPUT and connect to CUR OUTPUT terminals.

Current recorder interconnection cable specs are as follows:

- Distance the recorder from analyzer: 3000 feet (915 meters).maximum
- Load resistance: Less than 700 Ohms.
- Cable (user supplied): Two-conductor, shielded, min. 20 AWG

As supplied by the factory, the current output produces a zero of 4 mA. The current output may be adjusted to produce a zero of 0 mA as follows:

1. Zero the instrument as in Section 3-4. Adjust R23, the zero-adjust potentiometer on the Power Supply Board, to produce 0 mA current output.

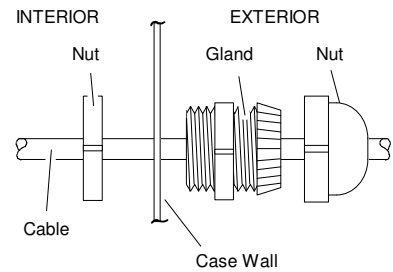

Figure 2-3. Cable Gland

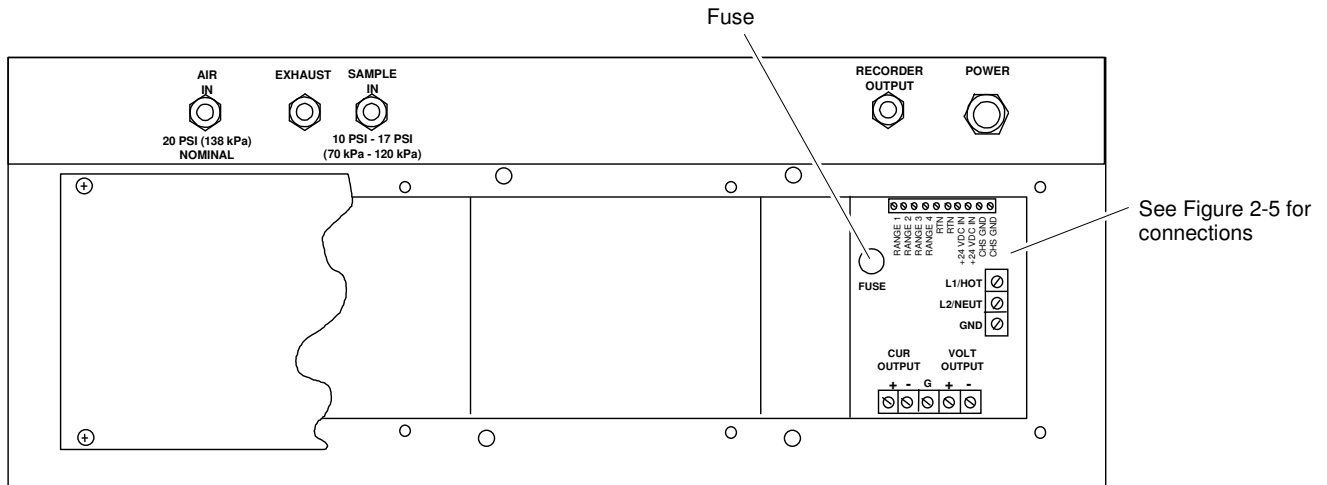

Figure 2-4. Rear View of Model 951C (cover removed)

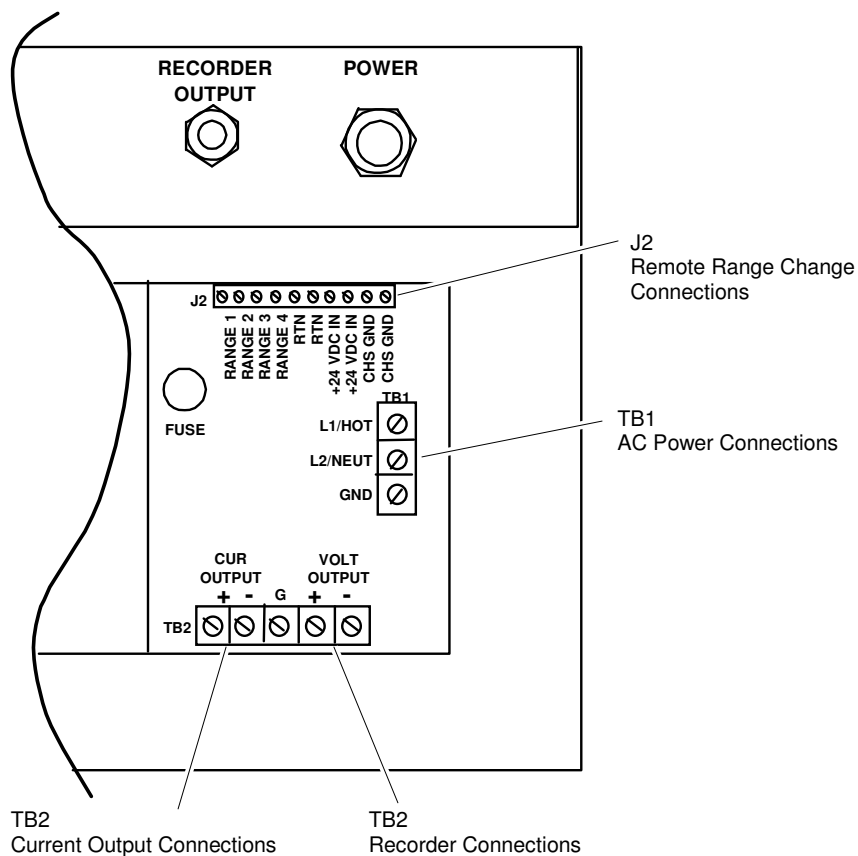

Figure 2-5. Rear Panel Wiring Connections

2-5 GAS REQUIREMENTS

The instrument requires two gases normally supplied from cylinders. They are:

a. Air (U.S.P. Breathing Grade)

This is used as both (a) an oxygen source for generation of the ozone required for the chemiluminescence reaction, and (b) a standard gas for zero calibration (nitrogen can also be used). Gas for each purpose must be supplied from a separate cylinder due to different pressure requirements at ozonator and zero inlets.

b. Span Gas

This is a standard gas of accurately known composition, used to set an upscale calibration point. The usual span gas is NO or NO₂ in a background of nitrogen.

WARNING

HIGH PRESSURE GAS CYLINDERS

This instrument requires periodic calibration with a known standard gas. See Section 3-3. See also General Precautions for Handling and Storing High Pressure Gas Cylinders, page P-5.

NOTE

For maximum calibration accuracy, the concentration of NO in the span gas should be similar to that in the sample gas. Also, the span gas should be supplied to the rear panel SAMPLE inlet at the same pressure as the sample gas. To ensure constant pressure, a pressure regulator may be utilized immediately upstream from the SAMPLE inlet.

Each gas used should be supplied from a tank or cylinder equipped with a clean, non-corrosive type, two-stage regulator. In addition, a shut-off valve is desirable. Install the gas cylinders in an area of relatively constant ambient temperature.

2-6 SAMPLE REQUIREMENTS

The sample must be clean and dry before entering the analyzer. In general, before admission to the analyzer, the sample should be filtered to eliminate particles larger than two microns and have a dew point below 90°F (32°C). The factory can provide technical assistance if desired.

Proper supply pressure for sample, zero and span gases for the Model 951C is 20 psig (138 kPa).

2-7 GAS CONNECTIONS

WARNING

TOXIC AND OXIDIZING GAS HAZARDS

This instrument generates ozone which is toxic by inhalation and is a strong irritant to throat and lungs. Ozone is also a strong oxidizing agent. Its presence is detected by a characteristic pungent odor.

The instrument exhaust contains both ozone and nitrogen dioxide, both toxic by inhalation, and may contain other constituents of the sample gas which may be toxic. Such gases include various oxides of nitrogen, unburned hydrocarbons, carbon monoxide and other products of combustion reactions. Carbon monoxide is highly toxic and can cause headache, nausea, loss of consciousness, and death.

Avoid inhalation of the ozone produced within the analyzer and avoid inhalation of the sample and exhaust products transported within the analyzer. Avoid inhalation of the combined exhaust products at the exhaust fitting.

Keep all tube fittings tight to avoid leaks. See Section 2-8 for Leak Test Procedure.

Connect rear exhaust outlet to outside vent by a 1/4 inch (6.3 mm) or larger stainless steel or Teflon line. Check vent line and connections for leakage.

1. Remove plugs and caps from all inlet and outlet fittings. (See Figure 2-4, page 2-3.)
2. Connect EXHAUST outlet to external vent via tubing with O.D. of 1/4-inch (6.3 mm) or larger. Use only stainless steel or Teflon tubing.
3. Connect external lines from ozonator air and sample sources to corresponding rear panel inlet ports. For sample line, stainless steel tubing is recommended.
4. Adjust regulator on ozonator air cylinder for output pressure of 20 to 25 psig (138 to 172 kPa). At least 20 psig should be present at rear of analyzer.
5. Supply sample gas to rear panel SAMPLE inlet at appropriate pressure: 20 psig (138 kPa). The nominal input pressure is 20 psig (138 kPa).

2-8 LEAK TEST

The following test is designed for sample pressure up to 5 psig (35 kPa).

1. Supply air or inert gas such as nitrogen at 5 psig (35 kPa) to analyzer sample and air input fittings.
2. Seal off analyzer exhaust fitting with a tube cap.
3. Use a suitable test liquid such as SNOOP (P/N 837801) to detect leaks. Cover all fittings, seals, or possible leak sources.
4. Check for bubbling or foaming which indicates leakage, and repair as required. Any leakage must be corrected before introduction of sample and/or application of electrical power.

For positive assurance that system is leak free, perform one of the tests in Section 5.0.

SECTION 3 OPERATION

3-1 FRONT PANEL INDICATORS AND CONTROLS

a. Display

The display is a 4-digit liquid crystal device which always displays NO_x concentration in parts-per-million. Figure 3-1 below.

b. Range Selection

The Model 951C has twelve customer selectable ranges, four LO ranges (10 ppm, 25 ppm, 100 ppm and 250 ppm), four MID ranges (20 ppm, 50 ppm, 200 ppm and 500 ppm), and four HI ranges (100 ppm, 250 ppm, 1000 ppm and 2500 ppm). The range is selected by positioning the PPM RANGE Switch (SW1) and the five configuration jumpers on the Signal Board to the desired range controlling the recorder output. Refer to Figure 3-2, page 3-2.

The Backlight will blink for values 10% in excess of the range maximum. Moving the switch to the right selects a higher fullscale value and restores the display.

c. Sample Pressure Gauge

The internal SAMPLE pressure (nominally 4 psig, 28 kPa) is adjusted by rotation of the Sample Pressure Regulator. See Figure 3-1 below.

NOTE

Using the MID ranges (20, 50, 200, and 500 ppm), set the sample pressure regulator to 2.5 psig, 17.5 kPa

d. Ozone Pressure

The OZONE pressure is determined by the pressure regulator of the air supply cylinder. A nominal pressure of 20 to 25 psig (138 to 172 kPa) is recommended. Proper operation is indicated when the front panel OZONE indicator lamp is lit.

NOTE

If ozone lamp does not light, increase pressure slightly by adjusting pressure regulator control on the air cylinder.

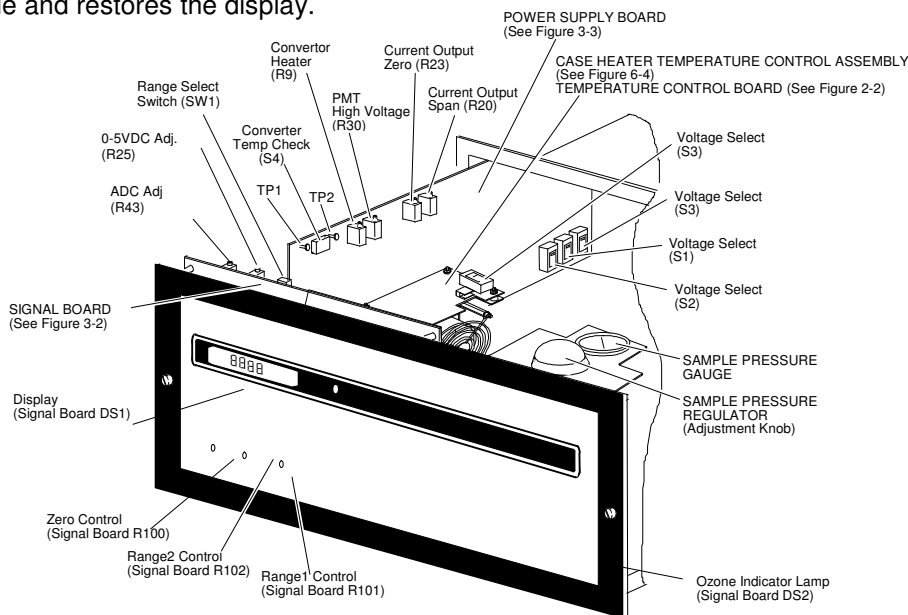

Figure 3-1. Model 951C Controls, Indicators and Adjustments

e. Zero and Span Potentiometers

See Figure 3-1 (page 3-1) and Figure 3-2 below. Screwdriver access holes through the front panel allow adjustments of the ZERO, RANGE1 and RANGE2 potentiometers (R100, R101 and R102 on the Signal Board).

f. Ozone Interlock

The ozone-producing UV lamp will not ignite or stay lit unless adequate air pressure is present at the AIR inlet (see Figure 2-4, page 2-3). Nominal setpoint pressure is 20 to 25 psig.

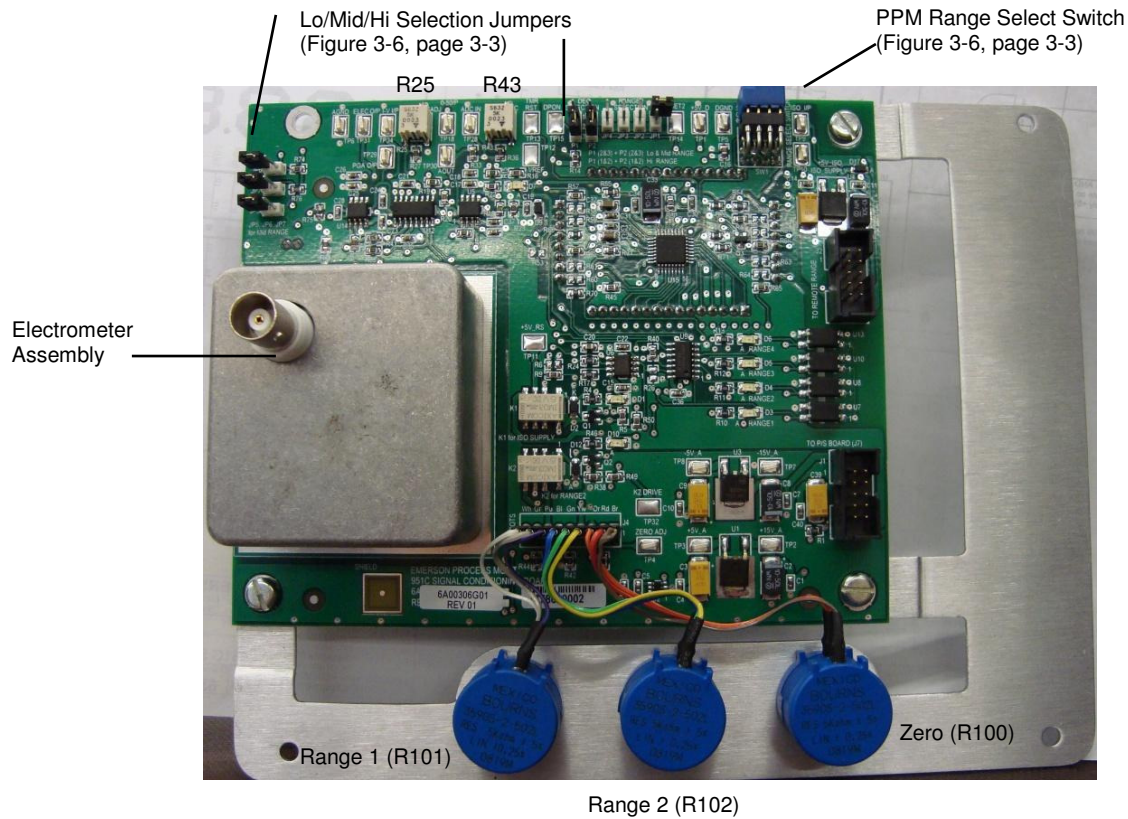

Figure 3-2. Signal Board



Figure 3-3. Signal Board Test Points

3-2 STARTUP PROCEDURE

The following are detailed instructions on startup and calibration.

1. Supply electrical power to the analyzer.
The analyzer will require approximately two hours for temperature equilibration before calibration.
2. On Signal Board, Figure 3-2, page 3-2:
 - a. Using a small flat screwdriver, set PPM RANGE Switch (Figure 3-6 below) to the range that will be used for sample analysis.

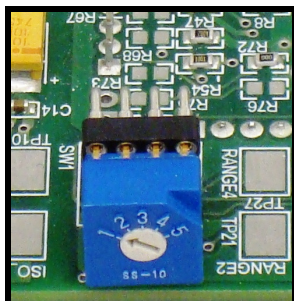
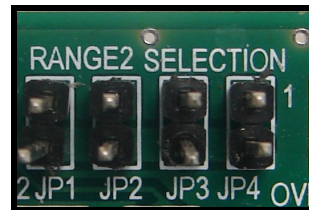

Figure 3-6. PPM Range Select Switch

Range (S1 Pos)	ppm Fullscale		
	Lo Range	Mid Range	Hi Range
1	10	20	100
2	25	50	250
3	100	200	1000
4	250	500	2500
Other	Remote	Remote	Remote

- c. Set Range2 Selection jumpers to Range 4, 2500ppm as shown in Figure 3-8 below.



Range Position	PPM Range		
	JP1	JP2	JP3
1	10	20	100
2	25	50	250
3	100	200	1000
4	250	500	2500

Figure 3-8. Range 2 Selection Jumpers

- b. Set Configuration Jumper Settings to desired position as shown in Figure 3-7 below.

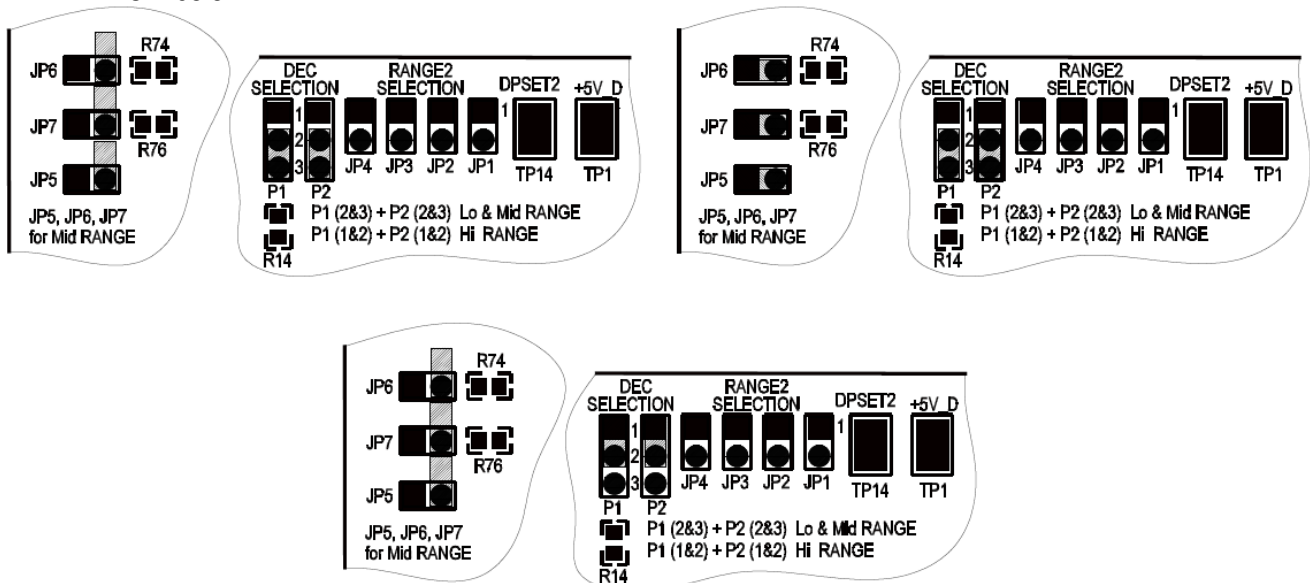

Figure 3-7. Configuration Jumper Settings

3. Establish correct pressure for air by the following:

- a. Adjust OZONE Pressure Regulator so that OZONE Pressure Gauge indicates 20 to 25 psig (138 to 172 kPa).
- b. To establish correct pressure of zero gas, supply zero gas to rear panel SAMPLE inlet. Note reading on internal SAMPLE Pressure Gauge. It should be the same as the nominal 4 psig (28 kPa) for the Lo and Hi Ranges and 2.5 psig for the Mid Range SAMPLE pressure indicated on the internal SAMPLE pressure gauge. This should remain constant when the analyzer input SAMPLE is switched from calibration gas standard to a zero gas standard. This may be assured by setting the delivery from the SAMPLE and the zero gas cylinder of span gas cylinder to the same value of delivery pressure, nominally 20 psig (138 kPa). If not, adjust output pressure regulator on zero gas cylinder as required.

4. Establish correct pressure of sample gas by the following:

- a. Supply sample gas to rear panel SAMPLE inlet.

- b. Adjust SAMPLE Backpressure Regulator so internal SAMPLE Pressure Gauge indicates the value appropriate to the desired operating range.

NOTE

Inability to obtain a flow of one liter per minute at the EXHAUST outlet usually indicates insufficient sample supply pressure at the SAMPLE inlet. Use a 2400 cc flowmeter (i.e., Brooks P/N 1350) at the EXHAUST outlet to measure flow.

5. Establish correct flow of upscale standard gas by the following:

- a. Supply upscale standard gas to rear panel SAMPLE inlet.
- b. Note reading on internal SAMPLE Pressure Gauge. It should be the same as in Step 3b.

NOTE

Supply pressures for sample and upscale standard gases must be the same. Otherwise, readout will be in error.

The analyzer is now ready for calibration.

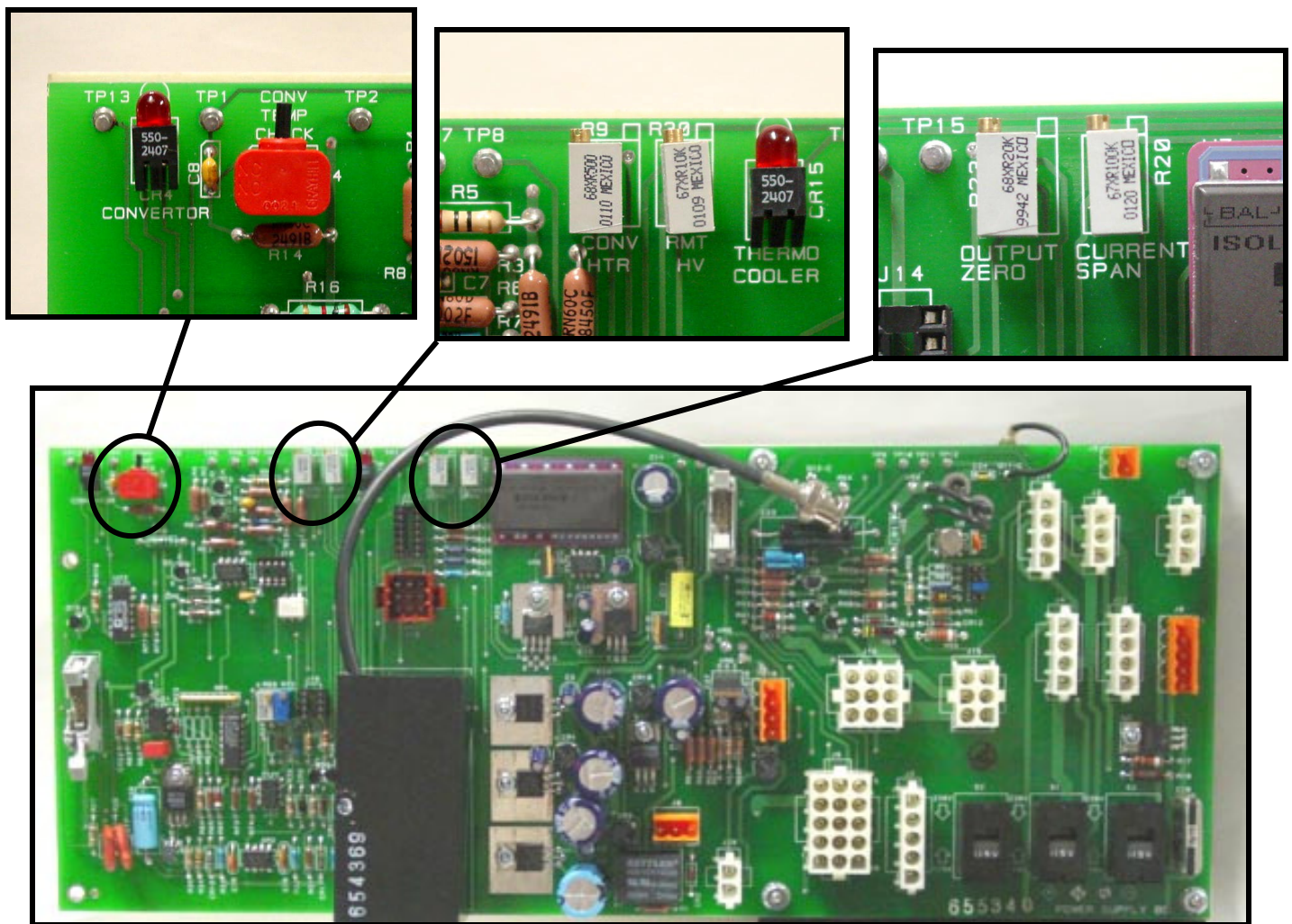

Figure 3-9. Power Supply Board

3-3 CALIBRATION

a. Zero Calibration

1. On the Signal Board (Figure 3-2, page 3-2), set PPM RANGE Switch (Figure 3-6, page 3-3) for the same range that will be used during sample analysis. Set front panel RANGE1 Control at about mid-range.
2. Supply zero gas to rear panel SAMPLE inlet.
3. Using the MID Range set the sample pressure regulator to 2.5 psig. Using the Lo or Hi ranges, set the sample pressure to 4.0 psig
4. After a stable reading is reached, adjust the zero by inserting a screwdriver in the ZERO slot on the front panel of the analyzer and turning until zero reading is obtained.

b. Upscale Calibration

1. On the Signal Board (Figure 3-2, page 3-2) set Upscale Calibration PPM RANGE Switch (Figure 3-6, page 3-3) to the position appropriate to the particular span gas.
2. Supply upscale standard gas of accurately known NO_x content to rear panel SAMPLE inlet.
3. Using the MID Range set the sample pressure regulator to 2.5 psig. Using the Lo or Hi ranges, set the sample pressure to 4.0 psig
4. Adjust front panel RANGE1 Control so that reading on display or recorder is equal to the known parts-per-million concentration of NO_x in the span gas. If the correct reading is not initially attainable by adjustment of the front panel RANGE1 Control, make the electronic adjustment in Step 5.

5. If necessary, increase sensitivity by raising photomultiplier voltage. Adjust R30 on the Power Supply Board (Figure 3-9) clockwise to increase (negative) the photomultiplier high voltage and sensitivity. This will interact with zero. Repeat Zero Calibration and Upscale Calibration (through step 3).
6. If necessary increase the upscale readings on the LCD display by adjusting potentiometer R43 until the display shows the correct span gas readings. Now, adjust R 25 so that reading on display and the recorder is equal to the known parts-per-million concentration of NO_x in the span gas.

3-4 ROUTINE OPERATION

After calibrating analyzer per Section 3-3, supply sample to SAMPLE inlet. Set PPM RANGE Switch (Figure 3-6, page 3-3) in appropriate position. The instrument will now continuously analyze the sample stream.

The Model 951C is designed for continuous operation. Normally, it is never turned off except for servicing or for a prolonged shutdown.

NOTE

During periods of shutdown, turn off the ozone lamp by shutting off the input air source.

3-5 CONVERTER TEMPERATURE ADJUSTMENT PROCEDURE

Once the appropriate high voltage and electronic gain have been selected such that the named calibration gas value is indicated by the Model 951C, the instrument is ready for adjustment of the converter temperature.

The vitreous carbon converter used in this analyzer has a low surface area which gradually increases during high temperature operation of the converter material.

Model 951C

Initially, the temperature of the peak of the converter efficiency starts at a relatively high value because significant heat must be supplied to make the converter active enough to reduce the input nitrogen dioxide to nitric oxide at the required 95% level. During the operation of the analyzer, the temperature of the peak will fall as the surface area of the converter is increased and less external energy is required to cause adequate conversion.

In extreme cases, where converter re-profiling has not been conducted, the converter is so active that it not only reduces nitrogen dioxide to nitric oxide, but it reduces the nitric oxide produced to nitrogen, which is not detected by the chemiluminescence reaction. The remedy in this case is to adjust the converter temperature to a lower value to improve the converter efficiency.

It is important that the converter temperature be periodically profiled to assure that it is running at its peak efficiency. An interval of one week is recommended. The nominal range of operational temperatures for the converter is 275°C to 400°C (527°F to 750°F). The operating temperature of the converter may be conveniently checked on the Power Supply Board (Figure 3-9, page 3-5) by momentarily depressing switch CONV TEMP CHECK (S4) while monitoring the resistance across terminals TP1 and TP2.

Table 3-1 allows for conversion of the observed resistance to the operating temperature for the converter.

Follow this procedure to optimize the operating temperature of the converter:

1. Power instrument and allow it to stabilize at operating temperature (one to two hours). Measure the operating temperature of the converter by the technique described above. Note the value for future reference.
2. Admit a calibration gas of known (NO₂) concentration into the analyzer and note the concentration value determined when the full response has been achieved.

3. Refer to Power Supply Board Figure 3-9, page 3-5. Turn the converter temperature adjust potentiometer (R9 CONV HTR) one turn *counterclockwise* from the setting established at the factory, and allow fifteen minutes for operation at the new lower temperature setpoint. Recheck the response and note the value for later use.
4. Increase the temperature of the converter by rotating the converter temperature adjust potentiometer (R9 CONV HTR) one quarter turn *clockwise*, wait fifteen minutes for thermal equilibrium and then re-measure the NO₂ calibration gas value. Note its value. Repeat this procedure of one quarter turn adjustments of the potentiometer, waiting for thermal stability and determination of the calibration gas value until either a 95% value is obtained or the final one quarter turn adjustment gives an efficiency increase of less than one percent.
5. Decrease the temperature of converter operation by rotating the converter temperature adjust potentiometer (R9 CONV HTR) one eighth of a turn *counterclockwise*. This places the converter at a temperature suitable for low ammonia interference and efficient NO₂ conversion. Re-measure the indicated converter temperature and compare it to the initially recorded value.

TEMPERATURE (°C)	RESISTANCE (Ohms)
0	400
25	438
100	552
200	704
250	780
300	856
350	932
400	1008
450	1084

Table 3-1. Resistance of Converter Temperature Sensor vs. Temperature

NOTE

**Converter temperature is not a direct
measure of converter efficiency.
Temperature measurement is for reference
purposes only.**

Model 951C

3-6 MEASUREMENT OF CONVERTER EFFICIENCY

It is the responsibility of the user to measure efficiency of the NO₂-to-NO converter during initial startup, and thereafter at intervals appropriate to the application (normally once a month).

Section 3-5 optimizes the operating temperature of the converter. It also serves as an efficiency check if the concentration of NO₂ in the calibration gas is documented accurate relative to National Institute of Standards and Technology (NIST) Reference Materials. If the concentration of the nitrogen dioxide calibration gas is not known accurately, this procedure still serves to adequately provide the correct converter operating temperature.

If the only available known standard is the nitric oxide calibration standard, the following procedure may be performed. This procedure checks converter efficiency through the utilization of gas-phase oxidation of nitric oxide into nitrogen dioxide over a range of nitrogen dioxide concentrations. This technique is abstracted and adapted from 40 CFR, Pt. 60, App. A, Method 20, Paragraph 5.6.

1. Select the appropriate instrument range.
2. Admit a nitric oxide in nitrogen NIST traceable calibration gas of a value between 45% and 55% of the instrument range selected to a clean, evacuated, leak tight Tedlar bag. Dilute this gas approximately 1:1 with a 20.9% oxygen, purified air.
3. Immediately attach the bag outlet to the input of the pump supplying pressurized gas to the analyzer. It is important to use a sample delivery pump which does not

consume nitrogen dioxide as it delivers sample to the analyzer. Losses of nitrogen dioxide in the pump will be reported as converter inefficiency.

4. Operate the analyzer and continue to sample the diluted nitric oxide sample for a period of at least thirty minutes. If the nitrogen dioxide to nitric oxide conversion is at the 100% level, the instrument response will be stable at the highest value noted.
5. If the response at the end of the thirty minute period decreases more than 2.0 percent of the highest peak value observed, the system is not acceptable and corrections must be made before repeating the check. If it is determined that observed subnormal conversion efficiencies are real, and not due to errors introduced by nitrogen dioxide consumption in the sample pump or other parts of the sample handling system, verify that the converter is peaked at the optimum temperature before replacing with a new converter.

3-7 RECOMMENDED CALIBRATION FREQUENCY

After initial startup or startup following a shutdown, the analyzer requires about two hours for stabilization before it is ready for calibration. Maximum permissible interval between calibrations depends on the analytical accuracy required, and therefore cannot be specified. It is recommended that initially the instrument be calibrated at least once every 8 hours. This practice should continue until experience indicates that some other interval is more appropriate.

SECTION 4 THEORY

4-1 NITRIC OXIDE DETERMINATION BY CHEMILUMINESCENCE METHOD

The chemiluminescence method for detection of nitric oxide (NO) is based on its reaction with ozone (O₃) to produce nitrogen dioxide (NO₂) and oxygen (O₂). Some of the NO₂ molecules thus produced are initially in an electronically excited state (NO₂*). These revert immediately to the ground state, with emission of photons (essentially red light).

The reactions involved are:

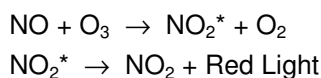

As NO and O₃ mix in the reaction chamber, the intensity of the emitted red light is proportional to the concentration of NO.

(Any NO₂ initially present in the sample is reduced to NO by a heated bed of vitreous carbon through which the sample is passed before being routed to the reaction chamber.)

The intensity of the emitted red light is measured by a photomultiplier tube (PMT), which produces a current of approximately 3 X 10⁻⁹ amperes per part-per-million of NO in the reaction chamber.

4-2 ANALYZER FLOW SYSTEM

The analyzer flow system is shown in drawing 2-0 and 3-0. Its basic function is to deliver regulated flows of sample, calibration gas, or zero gas and ozonized air to the reaction chamber. The discharge from the reaction chamber flows from the analyzer via the EXHAUST outlet.

a. Flow of Sample, Standard Gas or Zero Gas to Reaction Chamber

Suitably pressurized sample, standard gas or zero gas is supplied to the rear panel SAMPLE inlet.

The flow rate of the selected gas into the reaction chamber is controlled by a back pressure regulator inside the analyzer. It provides an adjustable, controlled pressure on the upstream side, where gas is supplied to the calibrated, flow-limiting sample capillary. The regulator is adjusted for appropriate reading on the internal SAMPLE Pressure Gauge. For operation at NO and NO₂ levels below 250 ppm, correct setting on the SAMPLE Pressure Gauge is 4 psig (28 kPa). This results in a flow of approximately 60 to 80 cc/min to the reaction chamber.

Excess sample is discharged with the effluent from the reaction chamber via the EXHAUST outlet. Bypass flow is set by the restrictor at 1 L/min (nominal) to ensure proper functioning of the SAMPLE Pressure Regulator and rapid system response. Excessive changes, on the order of 5 psig (35 kPa), in the pressure of the sample or standard gas will affect the bypass flow rate and can affect accuracy.

b. Ozone Generation

Suitably pressurized air from an external cylinder is supplied to the rear panel AIR inlet. The proper pressure setting is 20 to 25 psig (138 to 172 kPa). Within the ozone generator, a portion of the oxygen in the air is converted to ozone by exposure to an ultraviolet lamp. The reaction is:

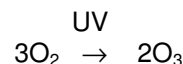

From the generator, the ozonized air flows into the reaction chamber for use in the chemiluminescence reaction.

4-3 SIGNAL CONDITIONING AND DISPLAY

A block diagram of the signal-processing electronics is shown in Figure 4-1, page 4-3.

The signal conditioning and display board provides the following functions:

- Signal conditioning circuit consisting of U14
- An analog to digital converter U15.
- Display device U15
- Range Control circuits U9 and U12
- Post signal amplifier and output amplifier circuit U5
- Display/Backlight blink control U5 and U6
- Range conditions.
- Remote Control Circuits

All of the above functions are on a single board located at the front of the instrument. Certain control requirements (ie) range calibration and zero offset adjustment are available as screw-driver adjustments via the front panel. A digital liquid crystal display is mounted on the rear side of the board for data display purposes as are control potentiometers.

a. Circuit Functions

Signal conditioning amplifiers

Boards assembly 6A00326G01/02 is a high input impedance electrometer amplifier board.

Current output from the detector unit is converted to voltage by the electrometer amplifier and then further amplified by post amplifier.

The electrometer amplifier gain may be reduced by a factor of 10 by shorting JP1 and by shorting pins 1 and 2 on P1 with the in-

cluded jumpers, this is used for higher range selection (ie) 100 to 2500 ppm NOx.

Gain Amplifier U14

The precision amplifier U14 allows 2 selectable gains, one for 10, 100, and 1000 spans and the other for 25, 250, and 2500 spans.

Intermediate gain ranges as required by the 951C Lo Range: 10, 25, 100, 250 ppm NOx, Mid Range: 20, 50, 200, 500 ppm NOx or Hi Range 100, 250, 1000, 2500 ppm NOx are obtained by interpolating between the requisite ranges using Boolean Logic and Analog Switches.

Range 1 and Range 2 selection

The signal output of U14 is adjusted at the front panel for instrument calibration purposes. Any second range may be chosen by placing a jumper on JP1, JP2, JP3, or JP4. When the programmed range is selected, the K2 relay toggles and allowing that range to be calibrated. Note! If no jumper is present only range 1 may be calibrated

Post Amplifiers U5

The conditioned signal from U14 and the range calibration potentiometers R101 and R102 are provided to U5. This amplifier has switch controlled feedback resistors that permit gain selections of any range, as determined by the range switch and associated logic. An Adjustment potentiometer R25 allows a small correction for inter range calibration purposes.

The output of U14 is provided to the Analog to Digital converter for digitization and display purposes. Potentiometer R43 allows adjustment of the signal to the ADC allowing concordance of display and recorder signals if required. Normally the ADC should be correctly calibrated during the factory test procedure and should not require further adjustment. Potentiometer R25 allows

recorder output adjustment to match display.

U5 is the recorder output amplifier. The output signal may be trimmed by R25 to precisely match the recorder calibration. Note that this adjustment does not affect or change the instrument display,

Analog to Digital Converter

U15 is a special integrated circuit with a built in ADC and LCD Drivers. The signal data is digitized and provided in the correct format to the liquid crystal display (LCD).

Display/Backlight and over range blink Circuits

The display circuits comprise of U15, no adjustments are required for these functions

The blink or over range display function uses U5, U6, and U9.

U5 is an analog comparator that senses an over range condition and turns on U6. U6 sets the blink rate for the Backlight.

Remote Control Circuits

The Model 951C is provided with a fully isolated remote control interface. Optical isolators and a remote 24V power supply ensure that no direct return path exists between the users system and the 951C When in the remote mode of operation.

Relay K1 switches between the internal range switch control (SW1) and the External Remote Range Control. When SW1 is on setting 5 it causes K1 to toggle and a fully isolated system is achieved.

Optical Isolators U7, U8, U10, and U13 connects via a ribbon cable to the remote connector panel at the rear of the 951C. A ten terminal barrier strip provides connection for remote range selection.

Connecting any input terminal 1 thru 4 to ground terminals 9 or 10 will select one of the four ranges.

For remote operation a 24V power supply should be connected to terminals 5,6 and 7,8, negative or low side is connected to 5, 6. Positive or high side to 7,8. For protection purposes the high side is fused. **Note! The local range switch SW1 must be in the fifth position (position Five) to disconnect local control and provide the return for remote control.**

For local operation Set the range switch SW1 between setting 1 thru 4. An external 24V supply is not required. SW1 is located on the top of the signal board.

4-4 ANALYZER THERMAL SYSTEM

The Analyzer Thermal System is shown in Figure 4-2, page 4-3. Its basic function is to provide a stable thermal environment for the PMT.

The temperature of the PMT must be held within a half-degree band at approximately 18°C if it is to produce a useful signal for low concentrations of NO_x. This is accomplished by means of a solid-state cooler which houses the PMT. The heat which is radiated from the cooler is carried away by the Cooler Fan.

The solid-state cooler must work against a relatively constant load in order to maintain the temperature of the PMT. This load is produced by a case heater and exhaust fan which control the temperature inside the case within a one-degree band (approximately 50°C for ambient temperatures from 4°C to 40°C).

The electronics which support the Analyzer Thermal System and the NO₂-to-NO Converter are contained on the Power Supply Board.

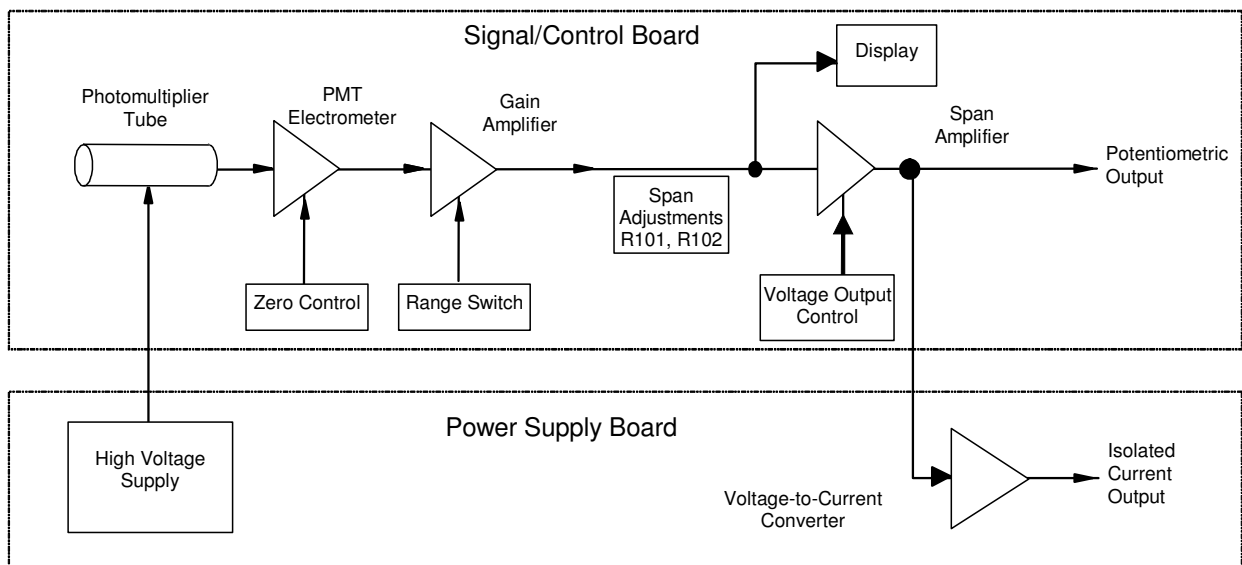

Figure 4-1. Analyzer Block Diagram

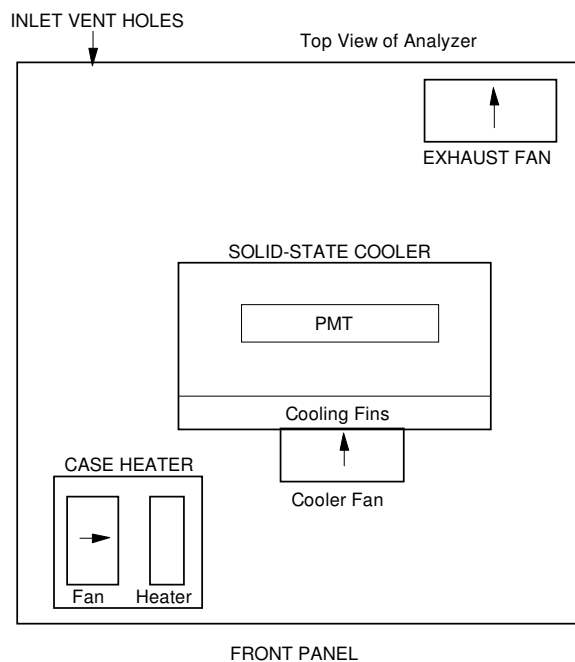

Figure 4-2. Analyzer Thermal System

SECTION 5 ROUTINE SERVICING

WARNING**ELECTRICAL SHOCK HAZARD**

Servicing requires access to live parts which can cause death or serious injury. Refer servicing to qualified personnel.

WARNING**INTERNAL ULTRAVIOLET LIGHT HAZARD**

Ultraviolet light from the ozone generator can cause permanent eye damage. Do not look directly at the ultraviolet source in ozone generator. Use of ultraviolet filtering glasses is recommended.

NOTE

The photomultiplier tube must not be exposed to ambient light. If the photomultiplier tube is exposed to light while the power is on, either through a loose fitting on the reaction chamber or any other leak, it will be destroyed. If exposed to ambient light with the power off, the tube will be noisy for some period of time. Unless appropriate precautions are observed, light can strike the tube upon removal of fittings from the reaction chamber.

5-1 SYSTEM CHECKS AND ADJUSTMENTS

The following procedures may be used to determine the cause of unsatisfactory instrument performance, or to make adjustments following replacement of components. If a recorder is available, use it for convenience and maximum accuracy in the various tests.

a. Display Fullscale Span Adjustment

If a recorder is used, and has been properly zeroed, it should agree with the display reading. If not, obtain agreement by adjustment of R25 on the Signal Board (see Figure 3-1 (page 3-1) and Figure 3-2 (page 3-2). If agreement cannot be reached, check the recorder. If the recorder is functioning properly, replace the Signal Conditioning Board.

b. Overall Sensitivity

Principal factors that determine overall sensitivity of the analyzer are the following: (a) sample flow rate to the reaction chamber, (b) sensitivity of the photomultiplier tube (PMT), and (c) PMT high voltage. If specified fullscale readings are unobtainable by adjustment of the SPAN Control, sensitivity is subnormal. The cause of reduced sensitivity may be in either the flow system (See Section 5-2, page 5-3) or the electronic circuitry (See Section 5-6, page 5-10).

If either the High Voltage Board or the Phototube/Reaction Chamber Assembly has been replaced, a readjustment of the high voltage will probably be required to obtain the correct overall sensitivity. Adjust R30 on the Power Supply Board (see Figure 3-1 page 3-1 and Figure 3-9 page 3-5) clockwise to increase (negative) the photomultiplier high voltage and sensitivity, or counterclockwise to decrease (negative) the voltage and sensitivity. The adjustment range is about -650 V to -2100 V for the regulated DC voltage applied to the photomultiplier tube. Nominal setting is -1100 volts. However, the voltage should be adjusted as required for overall system sensitivity.

c. Ozone Output

WARNING

TOXIC GAS HAZARD

Use extreme caution in troubleshooting the ozone generator. Ozone is toxic.

To check for adequate output from the ozone lamp, a convenient technique is to calibrate the analyzer on a high level NO standard such as 250 ppm NO at the nominal 4.0 psi internal sample pressure setpoint, and note the reading. The sample pressure setpoint is then sequentially set to pressures of 3.0, 2.0, and 1.0 psi after a stable span gas reading has obtained at the higher pressure setpoint. The span gas value will change as the pressure is changed. The difference in span gas value between two successive sample pressure levels should be approximately the same for the 4.0 to 3.0, 3.0 to 2.0, and 2.0 to 1.0 pressure steps.

If the size of the span gas value difference increases as the sample pressure is lowered, the analyzer output is limited by the amount of ozone production from the lamp and the two additional checks should be made. First, verify that the sample flow (not including bypass) does not exceed the nominal 60 to 80 cc/min, at 4.0 psi internal sample pressure. Second, substitute another lamp to see if the ozone output is increased.

If no other ozone lamp is available, the analyzer sample input pressure may be reduced to the pressure where the ozone limitation is not present. If the lamp output is low and the sample pressure is reduced to restore operation to the condition where ozone limitation is not occurring, some degradation in analyzer response time characteristics may occur.

d. Background Current

With zero air supplied to rear panel SAMPLE inlet, excessive background current is evidenced by the inability to obtain zero

display reading with adjustment of the ZERO Control. If this cannot be accomplished, the cause must be found and corrected. The fault may be in either the electronic circuitry or the sample flow system.

First, establish proper performance of the electronic circuitry. Turn on analyzer power. Verify that ZERO Control and amplifier are functioning properly. Then, check for excessive photomultiplier dark current and/or contamination of the reaction chamber or sample flow system as follows:

- Excessive Photomultiplier Dark Current

To check, shut off all flow to the ozone generator. Turn off ozone generator. Supply cylinder air to rear panel SAMPLE inlet. Note response on display or recorder. If background is still excessive, possible causes are:

leakage of ambient light to photomultiplier tube

defective photomultiplier tube

electrical leakage in socket assembly

- Contamination of Reaction Chamber or Sample Flow System.

See Section 5-4a, page 5-7.

5-2 SERVICING FLOW SYSTEM

To facilitate servicing and testing, the Model 951C has front drawer access.

Drawing 654090 shows flow system details, including fittings, thread specifications and connecting tubing.

a. Cleaning Sample Capillary

If clogging of sample capillary is suspected, measure flow rate as described below.

1. Turn off instrument power and shut off all gases.
2. Refer to Figure 6-1 (page 6-4) and Figure 6-2 (page 6-5). Cover and shade the fittings on the reaction chamber with a dark cloth or other light-shielding material. Remove the fitting associated with the sample capillary and place a cap over the open fitting to prevent entry of stray light.

NOTE

If the opened fitting is inadvertently exposed to ambient light, the instrument will temporarily give a highly noisy background reading. If so, this condition may be corrected by leaving the instrument on, with high voltage on, for several hours. If high voltage is on during exposure, the photomultiplier tube will be destroyed.

3. With instrument power off, supply suitable test gas (dry nitrogen or air) to rear-panel SAMPLE inlet.
4. Connect a flowmeter to open end of sample capillary. Adjust internal SAMPLE Pressure Regulator to normal operating setting of 4 psig (28 kPa). Verify that flowmeter indicates appropriate flow of 60 to 80 cc/min.
5. If flow is correct, restore analyzer to normal operation.
6. If flow is low, the capillary requires cleaning or replacement (Proceed with the step 7 below).
7. Clean capillary with denatured alcohol, and purge with dry nitrogen or air for one minute. Reconnect capillary.
8. With the photomultiplier still covered, slowly insert the free end of the capillary into the corresponding fitting on the reaction chamber. Push the capillary in until it touches bottom against the internal fitting. Then tighten fitting 1/4 turn past finger tight.

NOTE

Do not over-tighten capillary internal fitting, as over-tightened fittings may restrict the sample flow.

b. Ozone Restrictor Fitting

With instrument power off, supply suitable test gas (dry nitrogen or air) to rear panel AIR inlet. Cover photomultiplier housing with a dark cloth. At the fittings on the reaction chamber, disconnect the ozone tube and place a cap over the open fitting to prevent entry of ambient light. Connect a flowmeter to open end of ozone tube. Adjust the OZONE Pressure Regulator so that the OZONE Pressure Gauge indicates normal operating pressure of 20 to 25 psig (138 to 172 kPa). Verify that test flowmeter indicates an appropriate flow of 500 to 600 cc/min for 20 psig.

Subnormal flow indicates clogging in the flow path that supplies air to the ozone generator. This path contains a Restrictor (P/N 655519), consisting of a metal fitting with internal fritted (metal membrane) restrictor to reduce pressure. The fitting is upstream from the inlet port of the ozone generator. If the internal restrictor becomes plugged, the assembly (P/N 655519) must be replaced as it cannot normally be cleaned satisfactorily.

5-3 PHOTOMULTIPLIER TUBE/REACTION CHAMBER

This assembly consists of the photomultiplier tube and socket, the thermoelectric cooler, and the reaction chamber. Refer to Figure 6-1 (page 6-4) for location and details of mounting. Refer to Figure 6-2 (page 6-5) for information on the assembly.

The assembly must be removed from the analyzer in order to clean the reaction chamber or to replace the photomultiplier tube.

a. Removal

To remove the photomultiplier tube/reaction chamber assembly from the analyzer, do the following:

1. Disconnect power from the analyzer.
2. Release pressure from SAMPLE and AIR supplies.
3. Unplug the electrical cable from the Power Supply PC Board.
4. Disconnect the high-voltage cable and the signal cable from the left side of the assembly. Note the two mounting screws just below the connectors.
5. Uncouple the sample and ozone capillaries and the exhaust line from the right side of the assembly. Note the two mounting screws just below the fittings.
6. Loosen the screws described in steps 4 and 5 above.
7. Lift the assembly from the analyzer.
8. Replace the assembly by reversing the order of steps 1 through 7 above.

b. Cleaning Reaction Chamber

NOTE:

Photomultiplier tube will be permanently damaged if exposed to ambient light while powered with high voltage. Photomultiplier tube will develop temporary electronic noise if exposed to ambient light with high voltage OFF. A temporary noisy condition may be corrected by leaving instrument on, with high voltage on, for several hours. The required recovery time depends on intensity and duration of the previous exposure. Noise level on the most sensitive range usually drops to normal within 24 hours.

If sample gas is properly filtered, the reaction chamber should not require frequent cleaning. In event of carryover or contamination, however, the chamber should be disassembled to permit cleaning the quartz window and the optical filter. The following procedure is recommended.

1. Cover and shade the Reaction Chamber/Photomultiplier Assembly with a dark cloth or other light-shielding material.

NOTE

Always wear surgical rubber gloves when handling the reaction chamber to prevent contamination from handling.

2. Note the orientation of the fittings. Slowly rotate and withdraw the reaction chamber from the housing. Ensure that no light strikes the photomultiplier tube.
3. Unscrew plastic end cap, thus freeing the quartz window and the red plastic optical filter. Note the sequence in which these are assembled.
4. Clean the reaction chamber by the appropriate one of the following two methods, standard or alternate. The standard method is applicable in most cases. The alternate method is applicable when the instrument has shown high residual fluorescence. That condition is indicated by high residual currents on a zero gas and high differentials between zero gas readings obtained with the ozone lamp on and off.

Standard Cleaning Procedure

Using a stiff plastic bristle brush, such as a toothbrush, scrub the Teflon surface and gas ports of the reaction chamber with clean distilled water and Alconox* detergent (P/N 634929). Alconox detergent is included in the shipping kit provided with the Model 951C NO_x Analyzer, and is available from Sargent-Welch Scientific

Company under its catalog number S-195650-A.

Using Alconox and clean, soft facial tissue (NOT industrial wipes), carefully clean the quartz window. Vigorously flush reaction chamber and quartz window with clean distilled water. Blow out all possible water from internal passages of reaction chamber. Dry reaction chamber and quartz window in a warm oven at 125°F to 150°F (52°C to 66°C) for 30 to 45 minutes or purge-dry the parts with dry cylinder air or nitrogen to eliminate all moisture.

WARNING

ACID HAZARD

Hydrochloric acid (HC1) is a strong acid. It is irritating to the skin, mucous membranes, eyes and respiratory tract. Direct contact causes severe chemical burns.

Avoid Contact with eyes and skin and avoid breathing fumes. Use in hood or well ventilated place. Wear goggles, rubber gloves and protective clothing.

Alternate Cleaning Procedure - For High Residual Fluorescence

Holding the reaction chamber by the tube fittings, and using appropriate caution, immerse the white Teflon part of the chamber in 50% concentrated Reagent Grade hydrochloric acid. After five minutes, rinse thoroughly with de-ionized water, then air dry as in the standard cleaning method above.

Place parts in position and press on end-cap so that mating threads engage properly, without cross threading. Turn mating parts in one continuous motion until the parts mesh. Do not over-torque.

With reaction chamber now assembled, replace and reconnect it in reversed removal sequence. Orient as noted in step 2.

c. Photomultiplier Tube and Housing

The photomultiplier tube operates at high DC voltages (nominal setting is -1100 volts) and generates small currents that are highly amplified by the signal-conditioning circuitry. It is therefore important that ambient humidity and condensed water vapor be excluded from the interior of the photomultiplier housing. Ambient humidity can result in electrical leakage, observed as abnormally high dark current. Water vapor or condensed moisture in contact with the photomultiplier tube may result in an abnormally high noise level during instrument readout on zero air or upscale standard gas.

The Photomultiplier Tube/Reaction Chamber Assembly incorporates several features for exclusion of humidity and moisture. The photomultiplier socket assembly is potted with high impedance silicone rubber compound and is sealed from external influences with epoxy and rubber gasket material. The socket assembly and the reaction chamber are sealed with O-rings into opposite ends of the tubular photomultiplier housing. The socket end of the housing may be sealed with either one or two O-rings, depending on the length of the phototube.

d. Replacement of Photomultiplier Tube

The photomultiplier tube assembly must be removed from the housing in order to replace the tube. To remove, do the following:

1. Note the orientation of the connectors.
2. Slowly rotate and withdraw the socket assembly from the housing. Note the orientation and placement of the metal shield and the black plastic insulating cover.
3. Carefully unplug the photomultiplier tube from the socket.
4. Plug a new tube into the socket.

5. Orient the metal shield and black plastic insulator as noted in step 2.
6. Carefully rotate and insert the tube, shield and cover into the housing. Orient as noted in step 1.

5-4 OZONE GENERATION SYSTEM

This system consists of the ultraviolet lamp, lamp housing, and power supply. Refer to Figure 6-1 for location and details of mounting.

WARNING

TOXIC CHEMICAL HAZARD

The ozone generator lamp contains mercury. Lamp breakage could result in mercury exposure. Mercury is highly toxic if absorbed through skin or ingested, or if vapors are inhaled. Handle lamp assembly with extreme care.

If lamp is broken, avoid skin contact and inhalation in the area of the lamp or the mercury spill. Immediately clean up and dispose of the mercury spill and lamp residue as follows:

- Wearing rubber gloves and goggles, collect all droplets of mercury by means of a suction pump and aspirator bottle with long capillary tube. Alternatively, a commercially available mercury spill clean-up kit, such as J. T. Baker product No. 4439-01, is recommended.
- Carefully sweep any remaining mercury and lamp debris into a dust pan. Carefully transfer all mercury, lamp residue and debris into a plastic bottle which can be tightly capped. Label and return to hazardous material reclamation center.

Do not place in trash, incinerate or flush down sewer. Cover any fine droplets of mercury in non-accessible crevices with calcium polysulfide and sulfur dust.

a. Lamp/Housing Removal

To remove the lamp and housing, do the following:

1. Disconnect power from the instrument.
2. Release pressure from SAMPLE and AIR supplies.
3. Disconnect the air supply tubing from the front of the housing.
4. Disconnect the ozone tube leading to the reaction chamber.
5. Disconnect the power cable from the Power Supply.
6. Uncouple the two Velcro straps which secure the housing to power supply.
7. Lift the housing from the analyzer.

b. UV Lamp Replacement

To replace the lamp, do the following:

1. Unscrew and remove end cap.
2. Unscrew aluminum outer lamp housing tube from lamp base, using care not to hit or touch lamp assembly.

NOTE:

Do not touch lamp. Fingerprints may cause a decrease in lamp output.

3. Replace O-ring in lamp base with new O-ring supplied in kit.
4. Insert replacement lamp assembly using care not to hit or touch lamp housing.
5. Insert new O-ring into new end cap. Screw end cap onto end of lamp housing.

Replace the lamp and housing by reversing the steps in this section.

Model 951C

c. Power Supply Removal

To remove the Power Supply, do the following:

Refer to Figure 6-1.

1. Remove the lamp and housing as in Section 5-4b.
2. Disconnect the power lead from the Power Supply Board.
3. Remove the two screws which secure the Power Supply to the bottom plate of the analyzer.
4. Lift the Power Supply from the analyzer.
5. Replace the Power Supply by reversing the order of the steps in this section.

than the outlet tube. Further, the outlet tube and the sample capillary (P/N 615989) connect to the same stainless steel tee.

3. Release the assembly and disconnect the heater and sensor connectors from the temperature control board.
4. Remove the lacing from the heater blanket, and remove the converter tube. Note the position of the temperature sensor and its leads as the aluminum foil is unwrapped.
5. Replace the defective part and reassemble. The temperature sensor should contact the converter tube with the top of the sensor at the midpoint of the converter. Route sensor leads axially to the outer end.
6. Condition the converter as described in Sections 3-4 and 3-5.

5-5 CONVERTER ASSEMBLY

To check the heater blanket, verify the continuity of the heater coil.

To check the temperature sensor, refer to Section 3-4 and measure its resistance when instrument power is off (should be about 440 ohms) and when instrument power is on (should range from 800 to 1,000 ohms). See Table 3-1.

To remove the glass converter tube (see Figure 6-4):

1. Carefully disconnect the blue silicon connectors from the ends of the inlet and outlet tubes.
2. The inlet tube is partially filled with glass wool and has a larger inside diameter

5-6 SERVICING ELECTRONIC CIRCUITRY

For troubleshooting the electronic system, refer to Section 4.0 and the appropriate pictorial diagrams at the back of the manual. The electronic system utilizes printed circuit boards with solid-state components. After a malfunction is traced to a particular board, the recommended procedure is to return it to the factory for repair.

SECTION 6 REPLACEMENT PARTS

WARNING

PARTS INTEGRITY

Tampering with or unauthorized substitution of components may adversely affect safety of this product. Use only factory-approved components for repair.

6-1 MATRIX

Each analyzer is configured per the customer sales order. Below is the 951C sales matrix which lists the various configurations available.

To identify the configuration of an analyzer, locate the analyzer name-rating plate. The sales matrix identifier number appears on the analyzer name-rating plate.

Model	Description
951C	Process Chemiluminescence NOx Analyzer (19" Rack Mount) (951C)

Level 1	Ranges	
	01	Low Ranges: 0-10, 0-25, 0-100, 0-250 ppm NOx
	02	High Ranges: 0-100, 0-250, 0-1000, 0-2500 ppm NOx
	04	Mid Ranges: 0-20, 0-50, 0-200, 0-500 ppm NOx

Level 2	Output	
	01	Selectable: 0-5 VDC, 0/4-20 mA

Level 3	Case	
	01	Standard

Level 4	Spare	
4	00	None

Level 5	Sample Restrictor	
	01	Standard sample inlet, restrictor included
	02	User controlled sample flow (no sample restrictor included)

Model 951C

6-2 CIRCUIT BOARD REPLACEMENT POLICY

In most situations involving a malfunction of a circuit board, it is more practical to replace the board than to attempt isolation and replacement of the individual component. The cost of test and replacement will exceed the cost of a rebuilt assembly from the factory.

The following list does not include individual electronic components. If circumstances necessitate replacement of an individual component which can be identified by inspection or from the schematic diagrams, obtain the replacement component from a local source of supply.

6-3 REPLACEMENT PARTS

The following parts are recommended for routine maintenance and troubleshooting of the Model 951C NO_x Analyzer. If the troubleshooting procedures do not resolve the problem, contact your local Rosemount Analytical service office. A list of Rosemount Analytical Service Centers is located in Section 7.

a. Common Parts

Refer to Figure 6-1.

655519	Air Restrictor Fitting
657091	Capacitor Assembly
655166	Capillary, Bypass
655589	Capillary, Sample Hi
623719	Capillary, Sample Lo
654068	Temperature Control Assembly
654070	Converter Assembly
655303	Exhaust Fan
654052	Fan Assembly
898587	Fuse 3.15 A
902413	Fuse 6.25 A
654390	I/O Assembly
652173	Ozone Generator
658156	Ozone Generator UV Lamp Replacement Kit
655129	Ozone Generator Power Supply
654062	Photomultiplier Assembly
655332	Power Supply Assembly
662273	Pressure Switch
623936	Sample Flow Restrictor
644055	Sample Pressure Gauge
815187	Sample Regulator
622917	Sensor, Temperature
6A00337G01/02/03	Signal/Control Board
654878	Transformer/Inductor Assembly

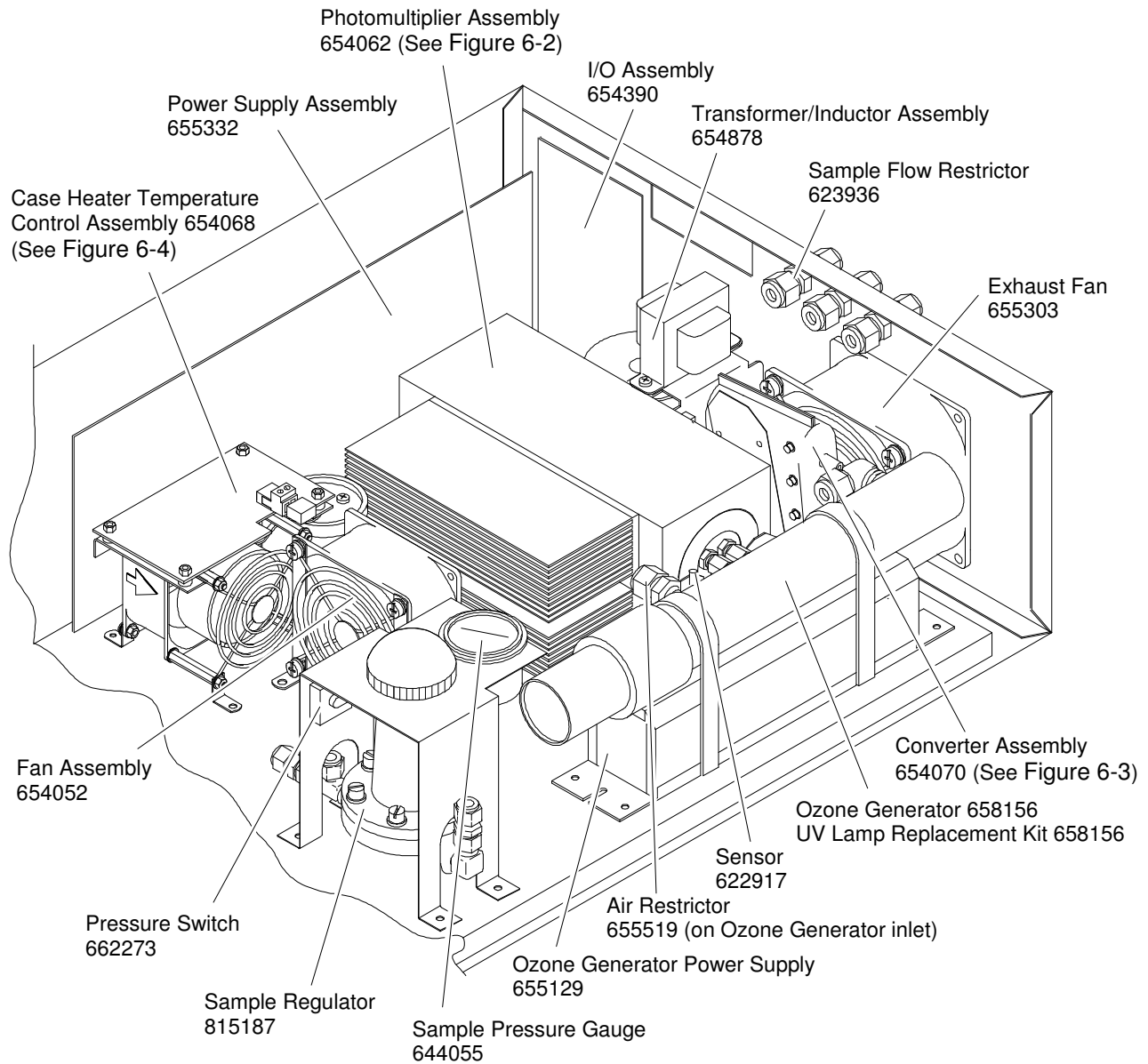

Figure 6-1. Major Assemblies of the Model 951C

b. Photomultiplier Assembly 654062

Refer to Figure 6-2.

- 654943 Housing
- 649541 Insulating Washer
- 636318 Magnetic Shield
- 630916 Magnetic Shield

- 001522 O-Ring
- 008423 O-Ring, Photomultiplier
- 655168 Photomultiplier Tube
- 654381 Reaction Chamber
- 654086 Socket Assembly
- 639722 Thermal Shield

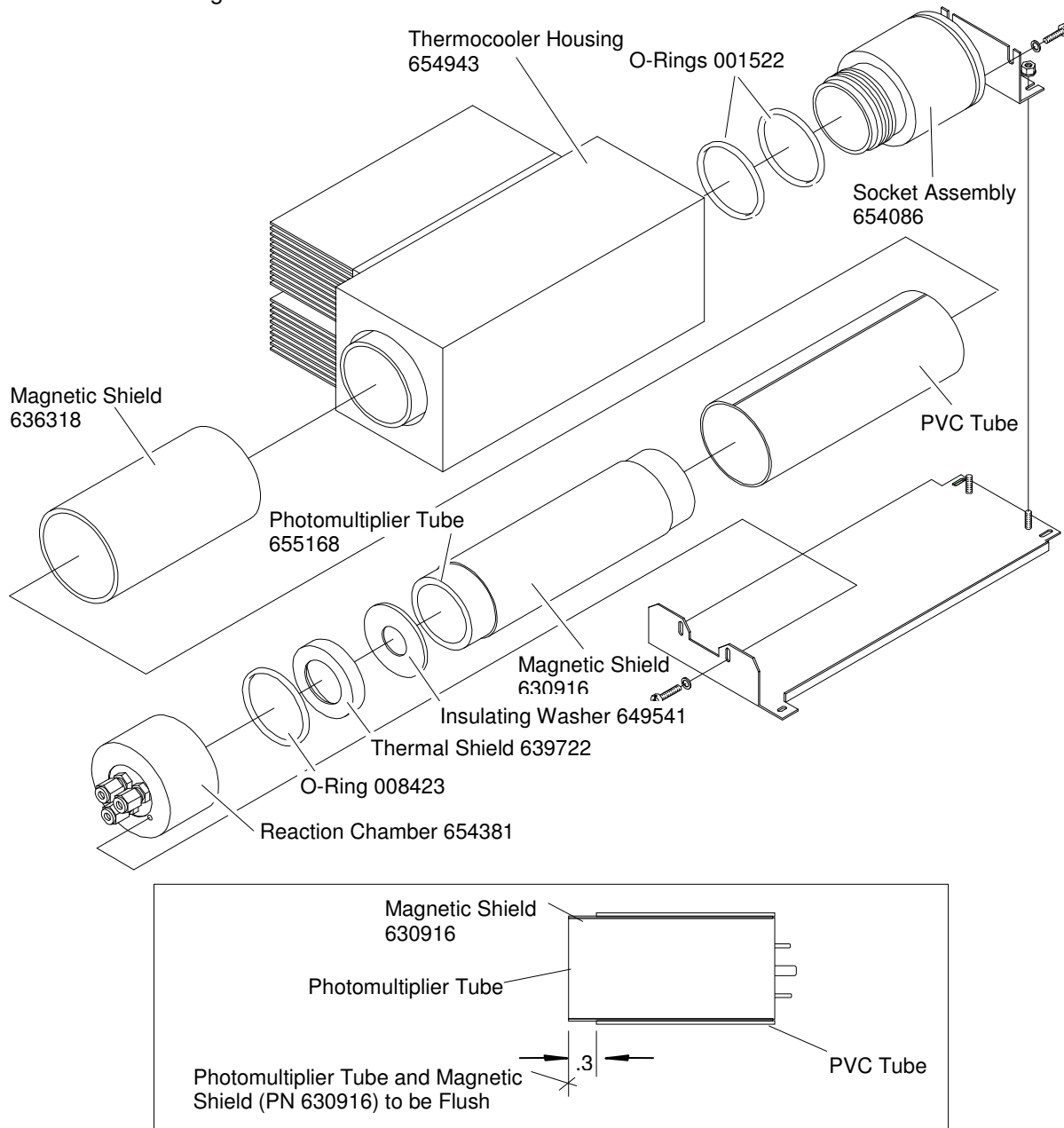

Note: Silicone lubricant to be applied to o-rings.

Figure 6-2. Photomultiplier Housing Assembly

c. Converter Assembly 654070

Refer to Figure 6-3.

- 632784 Connector, Blue Silicone
- 657127 Heater
- 632782 Temperature Sensor
- 632795 Tube

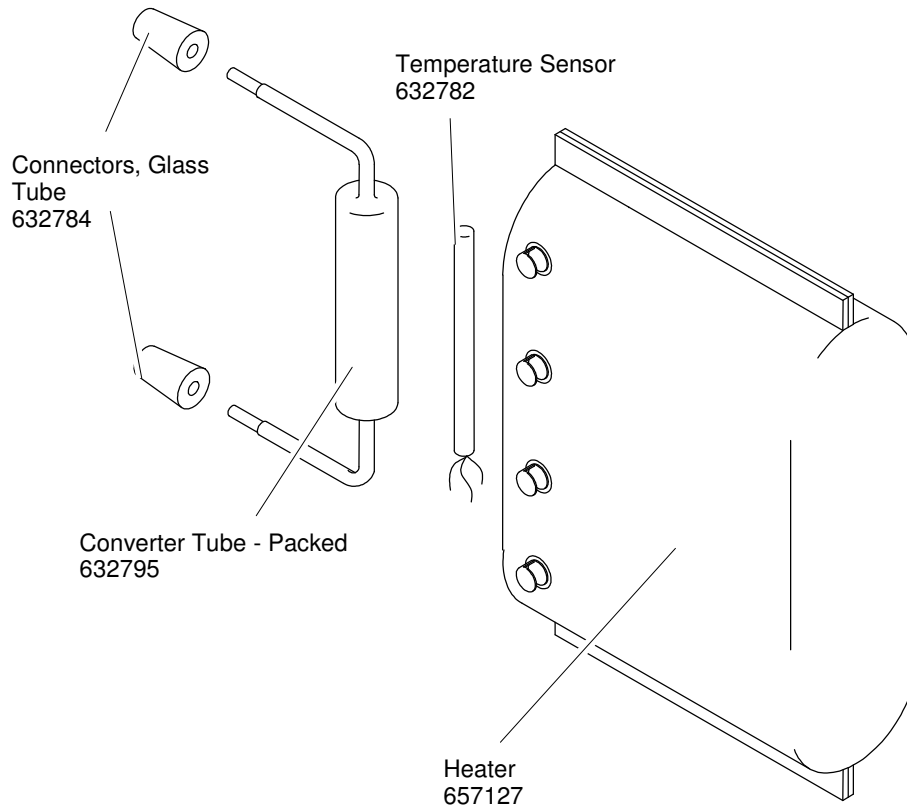

Figure 6-3. Converter Assembly

d. Temperature Control Assembly 654068

Refer to Figure 6-4.

- 622733 Fan
- 622732 Heater
- 655335 Temperature Control Board
- 900492 Thermal Fuse

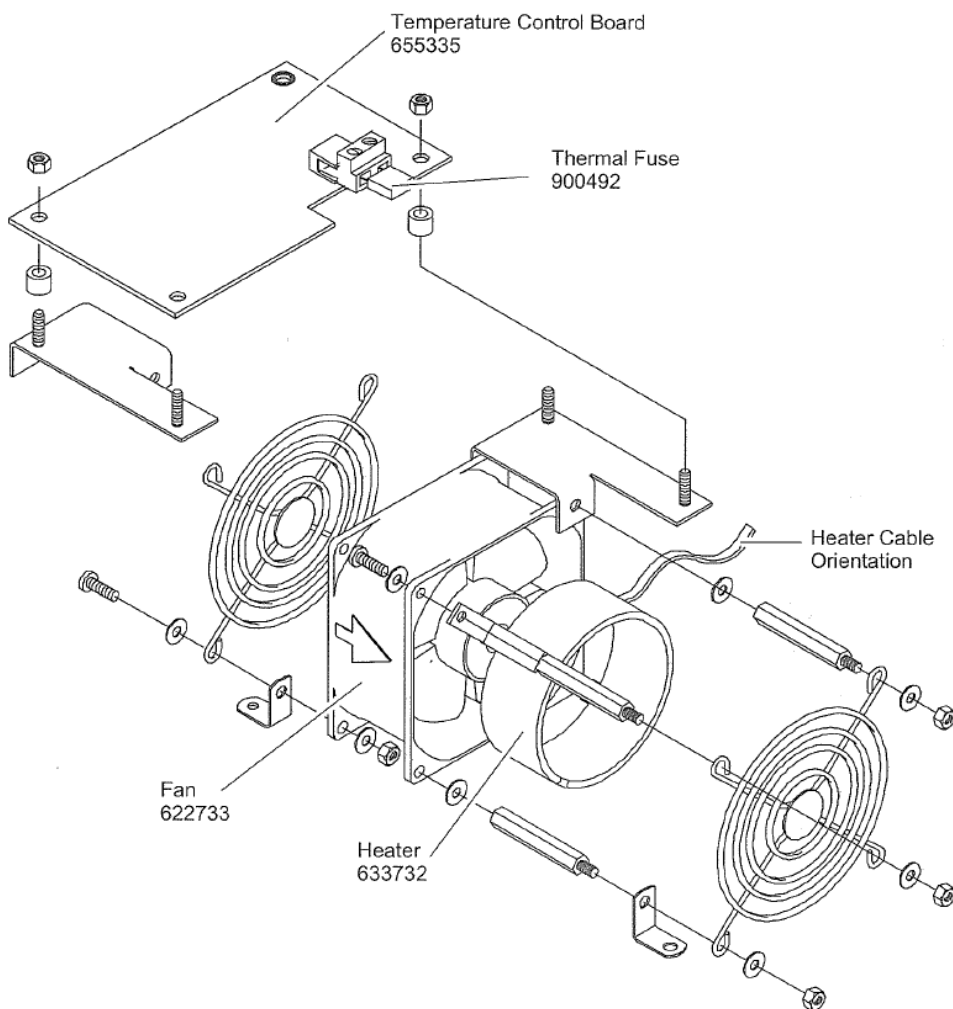

Figure 6-4. Case Heater Temperature Control Assembly

SECTION 7 RETURN OF MATERIAL

7-1 RETURN OF MATERIAL

If factory repair of defective equipment is required, proceed as follows:

1. Secure a return authorization from a Rosemount Analytical Inc. Sales Office or Representative before returning the equipment. Equipment must be returned with complete identification in accordance with Rosemount instructions or it will not be accepted.

Rosemount CSC (Customer Service Center) will provide the shipping address for your instrument.

In no event will Rosemount be responsible for equipment returned without proper authorization and identification.

2. Carefully pack the defective unit in a sturdy box with sufficient shock absorbing material to ensure no additional damage occurs during shipping.
3. In a cover letter, describe completely:
 - The symptoms that determined the equipment is faulty.
 - The environment in which the equipment was operating (housing, weather, vibration, dust, etc.).
 - Site from where the equipment was removed.
 - Whether warranty or non-warranty service is expected.
 - Complete shipping instructions for the return of the equipment.
4. Enclose a cover letter and purchase order and ship the defective equipment according to instructions provided in the Rosemount Return Authorization, prepaid, to the address provided by Rosemount CSC.

**Rosemount Analytical Inc.
Process Analytic Division
Customer Service Center
1-800-433-6076**

If warranty service is expected, the defective unit will be carefully inspected and tested at the factory. If the failure was due to the conditions listed in the standard Rosemount warranty, the defective unit will be repaired or replaced at Rosemount's option, and an operating unit will be returned to the customer in accordance with the shipping instructions furnished in the cover letter.

For equipment no longer under warranty, the equipment will be repaired at the factory and returned as directed by the purchase order and shipping instructions.

7-2 CUSTOMER SERVICE

For order administration, replacement Parts, application assistance, on-site or factory repair, service or maintenance contract information, contact:

**Rosemount Analytical Inc.
Process Analytic Division
Customer Service Center
1-800-433-6076**

7-3 TRAINING

A comprehensive Factory Training Program of operator and service classes is available. For a copy of the *Current Operator and Service Training Schedule* contact :

**Rosemount Analytical Inc.
Process Analytic Division
Customer Service Center
1-800-433-6076**

SECTION 8 INDEX

2

230 VAC conversion, 2-3

A

Air (U.S.P. Breathing Grade), 2-5

AIR inlet

adequate air pressure, 3-3

setpoint pressure, 3-3

analyzer

installation location, 2-3

mount near sample, 2-3

operating temperature, 2-3

warm-up, 7, 3-3

C

Contamination of Reaction Chamber or Sample Flow System, 5-2

converter

glass converter tube, 5-7

heater blanket, 5-7

measuring efficiency, 3-9

optimizing operating temperature, 3-7

temperature check, 3-7

temperature sensor, 5-7

converter temperature

adjustment, 3-7

recommended periodic check, 3-7

current output

adjustment, 2-3

Current recorder connections

cable specifications, 2-3

hookup, 2-3

routing, 2-3

cylinders, air/gas

location, 2-3

D

display, 3-1

DP SELECT jumpers, 3-3

E

Establish correct flow of upscale standard gas, 3-4

Establish correct pressure for air, 3-4

Establish correct pressure of sample gas, 3-4

establish correct pressure of zero gas, 3-4

Excessive Photomultiplier Dark Current, 5-2

F

flow rate, measuring, 5-3

flow rate, subnormal, 5-3

I

Inability to obtain a flow of one liter per minute at the EXHAUST outlet, 3-4

internal SAMPLE pressure, 3-1

adjustment, 3-1

O

output connections

routing, 2-3

ozonator air

supply pressure, 7

ozone generation system, description, 5-6

ozone generation system, power supply removal, 5-7

ozone generation system, removal, 5-6

ozone generation system, UV lamp replacement, 5-7

ozone lamp

output check, 5-2

OZONE pressure

determination, 3-1

nominal, 3-1

P

photomultiplier tube, 1-1, 4-1, 5-1, 5-2, 5-3, 5-4, 5-6

photomultiplier tube, description, 5-5

potentiometric recorder connections

cable specifications, 2-3

hookup, 2-3

routing, 2-3

Power connections

cable type, 2-3

hookup, 2-2

routing, 2-3

PPM RANGE Switch, 3-3

R

Range2 Select jumpers, 3-3

reaction chamber, 4-1, 4-2, 5-1, 5-2, 5-3, 5-4, 5-5, 5-6

reaction chamber, alternate cleaning procedure, 5-5

reaction chamber, standard cleaning procedure, 5-5

Return Authorization, 7-2

S

sample gas

 establish correct pressure, 7

 supply pressure, 7

shutdown, 3-6

Span Gas, 2-5

supply pressure, 2-5

T

thermoelectric cooler, 5-4

U

Upscale Calibration, 8

 PPM RANGE switch, 3-6

 RANGE1 control, 3-6

 sensitivity, 3-6

 supply gas, 3-6

Z

Zero Calibration, 7

 PPM RANGE switch, 3-6

 RANGE1 control, 3-6

 ZERO control, 3-6

zero display reading, inability to obtain, 5-2

zero gas

 establish correct pressure, 7

 supply pressure, 7

LIST OF DRAWINGS

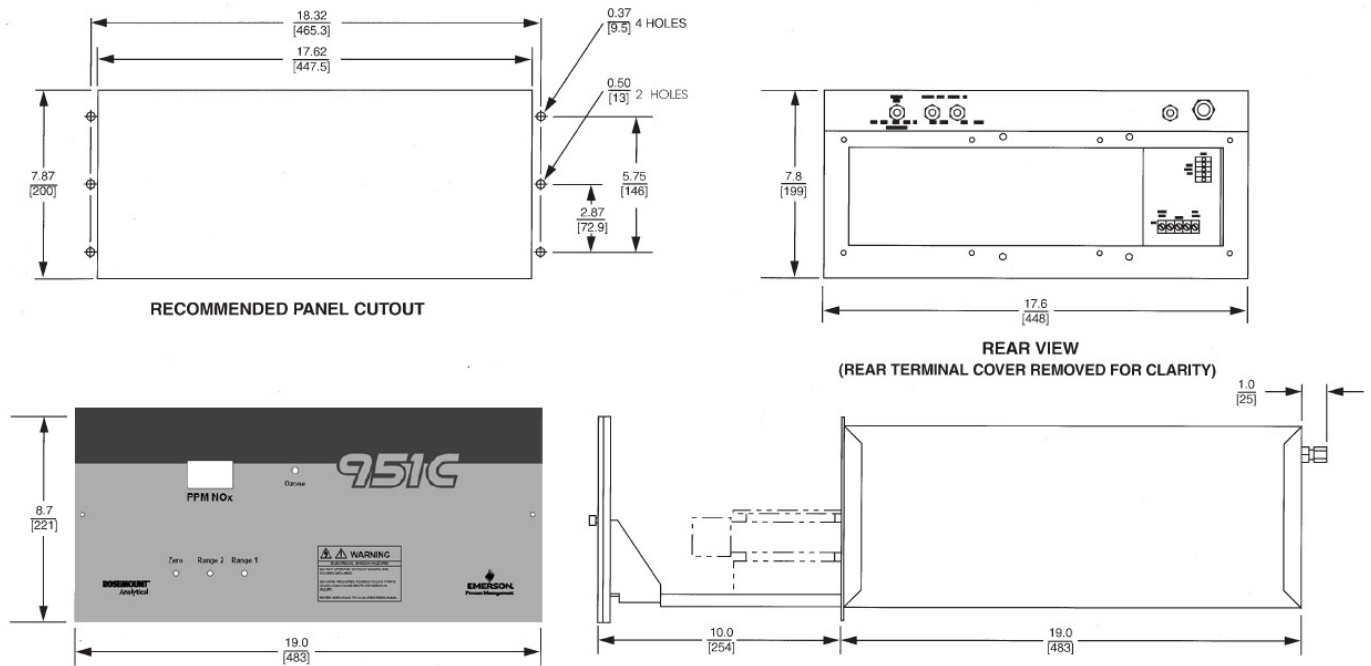

Drawing 1-1. Panel Cutout / Installation Drawing

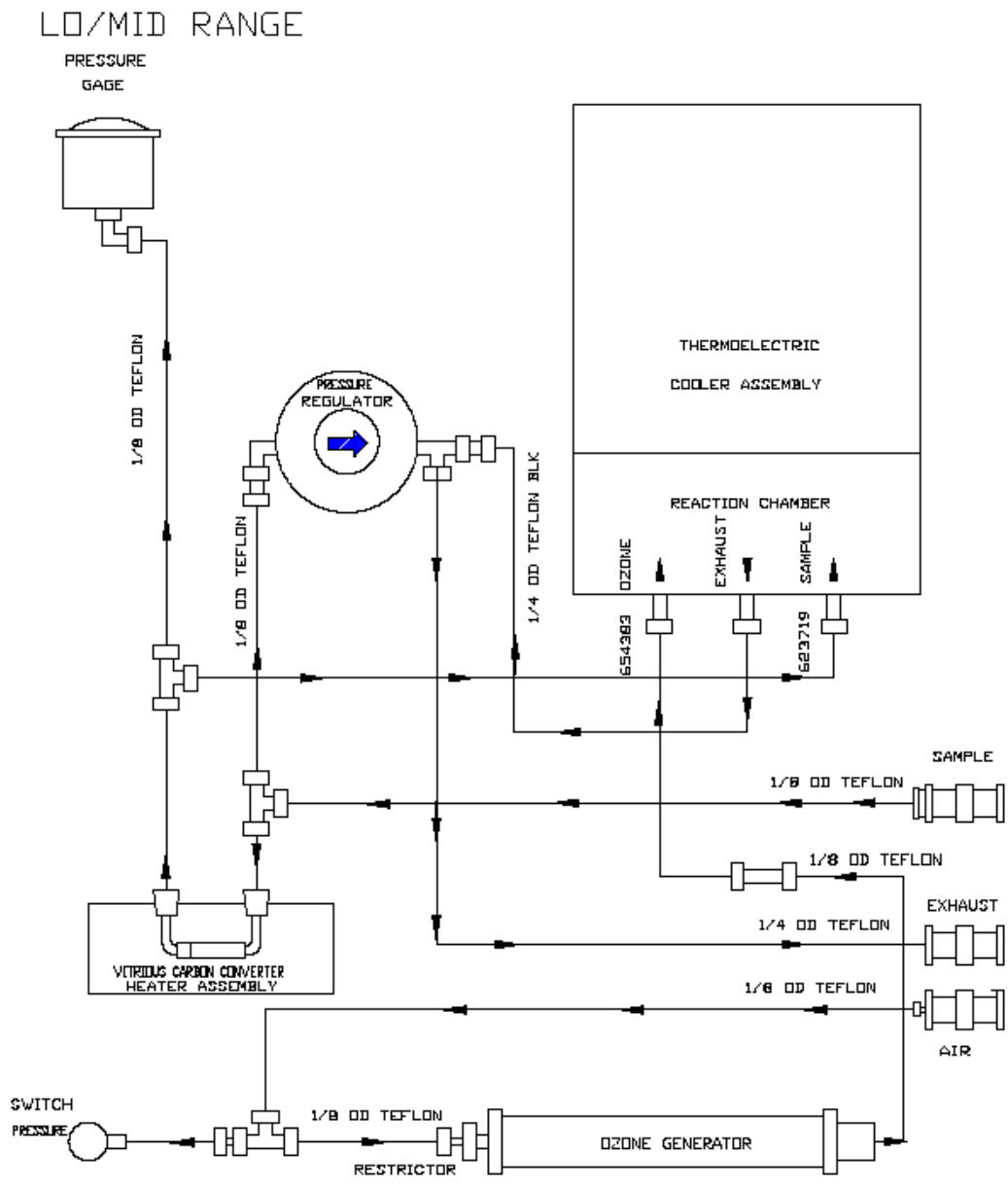

Drawing 1-2 Flow Diagram, Lo/Mid Range

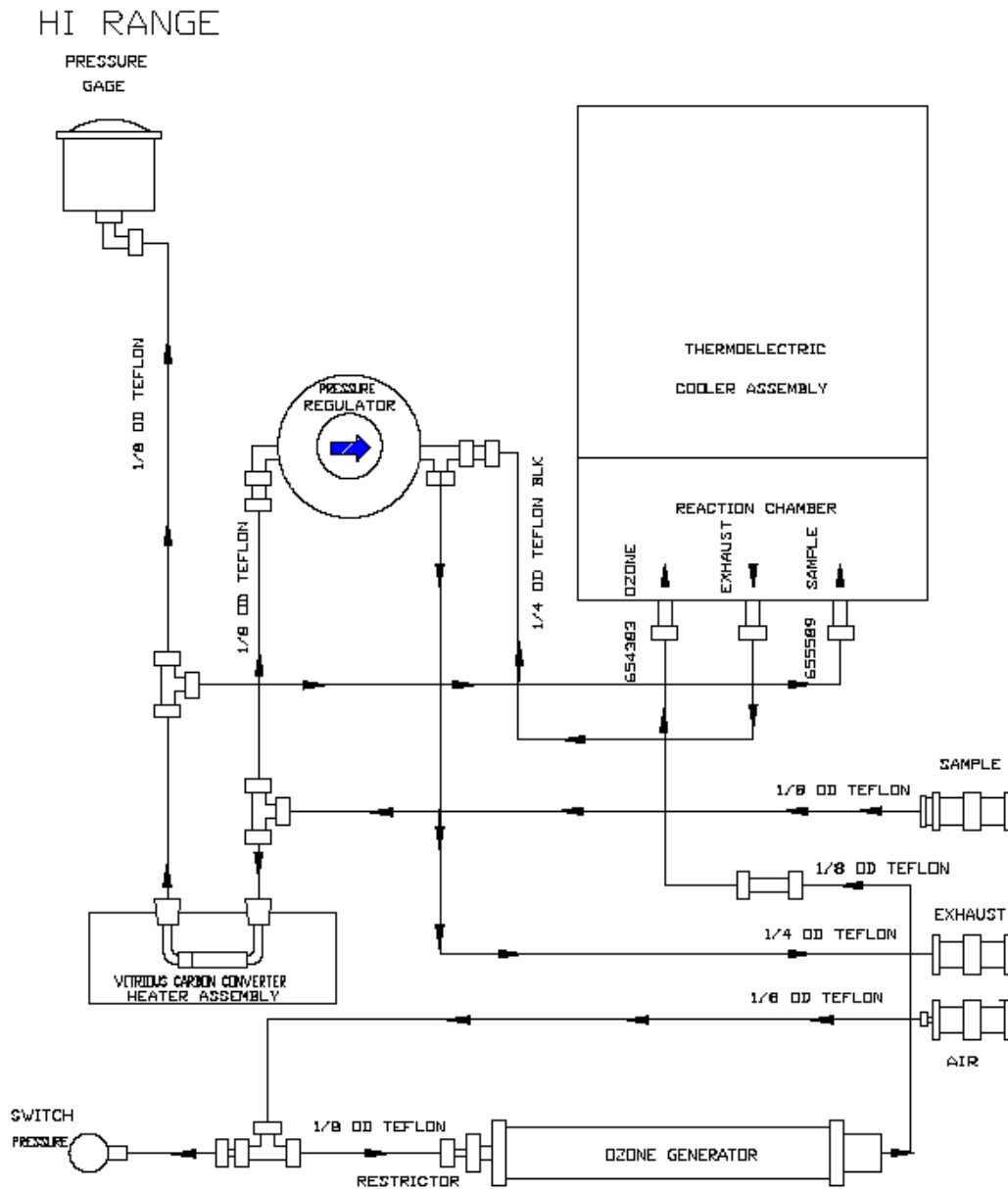

Drawing 1-3 Flow Diagram, Hi Range

WARRANTY

Goods and part(s) (excluding consumables) manufactured by Seller are warranted to be free from defects in workmanship and material under normal use and service for a period of twelve (12) months from the date of shipment by Seller. Consumables, glass electrodes, membranes, liquid junctions, electrolyte, o-rings, etc., are warranted to be free from defects in workmanship and material under normal use and service for a period of ninety (90) days from date of shipment by Seller. Goods, part(s) and consumables proven by Seller to be defective in workmanship and/or material shall be replaced or repaired, free of charge, F.O.B. Seller's factory provided that the goods, part(s) or consumables are returned to Seller's designated factory, transportation charges prepaid, within the twelve (12) month period of warranty in the case of goods and part(s), and in the case of consumables, within the ninety (90) day period of warranty. This warranty shall be in effect for replacement or repaired goods, part(s) and the remaining portion of the ninety (90) day warranty in the case of consumables. A defect in goods, part(s) and consumables of the commercial unit shall not operate to condemn such commercial unit when such goods, part(s) and consumables are capable of being renewed, repaired or replaced.

The Seller shall not be liable to the Buyer, or to any other person, for the loss or damage directly or indirectly, arising from the use of the equipment or goods, from breach of any warranty, or from any other cause. All other warranties, expressed or implied are hereby excluded.

IN CONSIDERATION OF THE HEREIN STATED PURCHASE PRICE OF THE GOODS, SELLER GRANTS ONLY THE ABOVE STATED EXPRESS WARRANTY. NO OTHER WARRANTIES ARE GRANTED INCLUDING, BUT NOT LIMITED TO, EXPRESS AND IMPLIED WARRANTIES OR MERCHANTABILITY AND FITNESS FOR A PARTICULAR PURPOSE.

Limitations of Remedy. SELLER SHALL NOT BE LIABLE FOR DAMAGES CAUSED BY DELAY IN PERFORMANCE. THE SOLE AND EXCLUSIVE REMEDY FOR BREACH OF WARRANTY SHALL BE LIMITED TO REPAIR OR REPLACEMENT UNDER THE STANDARD WARRANTY CLAUSE. IN NO CASE, REGARDLESS OF THE FORM OF THE CAUSE OF ACTION, SHALL SELLER'S LIABILITY EXCEED THE PRICE TO BUYER OF THE SPECIFIC GOODS MANUFACTURED BY SELLER GIVING RISE TO THE CAUSE OF ACTION. BUYER AGREES THAT IN NO EVENT SHALL SELLER'S LIABILITY EXTEND TO INCLUDE INCIDENTAL OR CONSEQUENTIAL DAMAGES. CONSEQUENTIAL DAMAGES SHALL INCLUDE, BUT ARE NOT LIMITED TO, LOSS OF ANTICIPATED PROFITS, LOSS OF USE, LOSS OF REVENUE, COST OF CAPITAL AND DAMAGE OR LOSS OF OTHER PROPERTY OR EQUIPMENT. IN NO EVENT SHALL SELLER BE OBLIGATED TO INDEMNIFY BUYER IN ANY MANNER NOR SHALL SELLER BE LIABLE FOR PROPERTY DAMAGE AND/OR THIRD PARTY CLAIMS COVERED BY UMBRELLA INSURANCE AND/OR INDEMNITY COVERAGE PROVIDED TO BUYER, ITS ASSIGNS, AND EACH SUCCESSOR INTEREST TO THE GOODS PROVIDED HEREUNDER.

Force Majeure. Seller shall not be liable for failure to perform due to labor strikes or acts beyond Seller's direct control.

Instruction Manual

748214-V

June 2009

Model 951C

WORLD HEADQUARTERS AND AMERICAS

Emerson Process Management Rosemount Analytical Inc.

6565 P Davis Industrial Parkway
Solon, OH 44139 USA
T 440.914.1261
Toll Free in US and Canada 800.433.6076
F 440.914.1271
e-mail: gas.csc@Emerson.com
www.raihome.com
National Response Center 800.654.7768

ASIA-PACIFIC

Emerson Process Management Asia Pacific Private Limited

1 Pandan Crescent
Singapore 128461
Republic of Singapore
T 65 6 777 8211
F 65 6 777 0947
e-mail: analytical@ap.emersonprocess.com

ROSEMOUNT ANALYTICAL EUROPE

Emerson Process Management GmbH & Co. OHG

Industriestrasse 1
63594 Hasselroth
Germany
T 49 6055 884 0
F 49 6055 884209

EUROPE

Emerson Process Management Shared Services Limited

Heath Place
Bognor Regis
West Sussex PO22 9SH
England
T 44 1243 863121
F 44 1243 845354

LATIN AMERICA

Emerson Process Management Rosemount Analytical

11100 Brittmoore Park Road
Houston, TX 77041 USA
T 713.467.6000
F 713.827.3328F 49 6055 884209

MIDDLE EAST AND AFRICA

Emerson Process Management

EPM Building
P.O. Box 17033
Jebel Ali Free Zone
Dubai, United Arab Emirates
T 971 4 8835235
F 971 4 8835312



EMERSON[™]
Process Management